

HEAT CONTROLLER, INC.

INSTALLATION, OPERATION
& MAINTENANCE MANUAL

**Residential Packaged
Geothermal Heat Pump**

HEV/H Series
2 to 5 Tons

TABLE OF CONTENTS

Model Nomenclature	3
Safety Instructions	4
Pre-Installation.....	5
Physical Data.....	6
Vertical Unit Dimensions.....	7-8
Vertical Installation.....	9
Water Connection Installation.....	14
Ground-Loop Heat Pump Applications	15-16
Ground-Water Heat Pump Applications.....	17
Water Quality Standards	18
Hot Water Generator	19-21
Electrical Data	22-26
Blower Performance Data	27-28
Wiring Diagrams	29
DXM2 Controls	30-31
Unit Start-Up and Operating Conditions.....	32-38
Preventive Maintenance	39
Troubleshooting.....	40-44

UNIT NOMENCLATURE

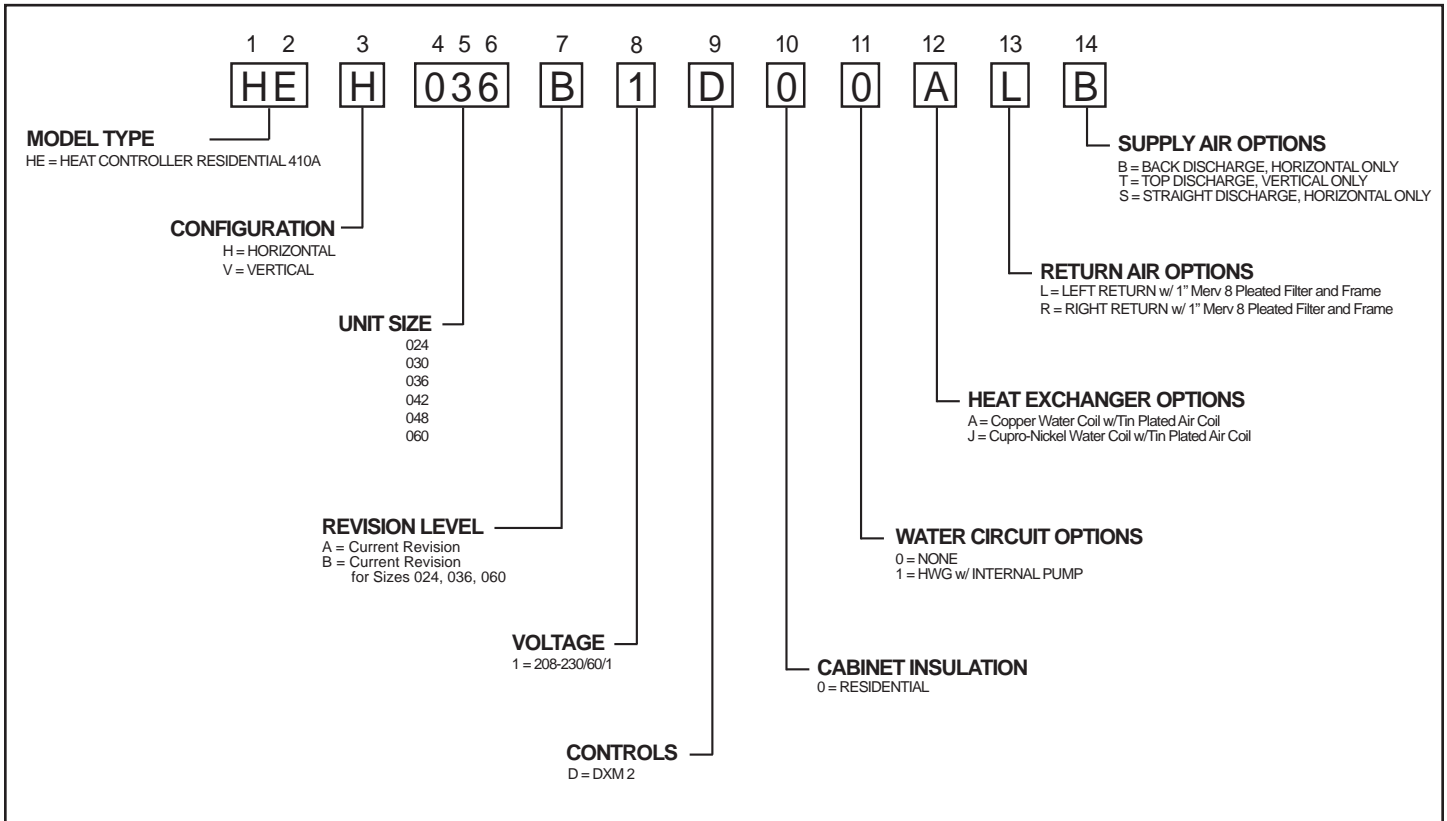

Safety

Warnings, cautions and notices appear throughout this manual. Read these items carefully before attempting any installation, service or troubleshooting of the equipment.

DANGER: Indicates an immediate hazardous situation, which if not avoided will result in death or serious injury. DANGER labels on unit access panels must be observed.

WARNING: Indicates a potentially hazardous situation, which if not avoided could result in death or serious injury.

CAUTION: Indicates a potentially hazardous situation or an unsafe practice, which if not avoided could result in minor or moderate injury or product or property damage.

NOTICE: Notification of installation, operation or maintenance information, which is important, but which is not hazard-related.

▲ WARNING! ▲
WARNING! Verify refrigerant type before proceeding. Units are shipped with R-410A refrigerant.
▲ WARNING! ▲
WARNING! To avoid the release of refrigerant into the atmosphere, the refrigerant circuit of this unit must be serviced only by technicians who meet local, state, and federal proficiency requirements.

▲ WARNING! ▲
WARNING! All refrigerant discharged from this unit must be recovered WITHOUT EXCEPTION. Technicians must follow industry accepted guidelines and all local, state, and federal statutes for the recovery and disposal of refrigerants. If a compressor is removed from this unit, refrigerant circuit oil will remain in the compressor. To avoid leakage of compressor oil, refrigerant lines of the compressor must be sealed after it is removed.
▲ CAUTION! ▲
CAUTION! To avoid equipment damage, DO NOT use these units as a source of heating or cooling during the construction process. The mechanical components and filters will quickly become clogged with construction dirt and debris, which may cause system damage.

GENERAL INFORMATION

Inspection

Upon receipt of the equipment, carefully check the shipment against the bill of lading. Make sure all units have been received. Inspect the packaging of each unit, and inspect each unit for damage. Insure that the carrier makes proper notation of any shortages or damage on all copies of the freight bill and completes a common carrier inspection report. Concealed damage not discovered during unloading must be reported to the carrier within 15 days of receipt of shipment. If not filed within 15 days, the freight company can deny the claim without recourse. Note: It is the responsibility of the purchaser to file all necessary claims with the carrier. Notify Heat Controller of all damage within fifteen (15) days of shipment.

Storage

Equipment should be stored in its original packaging in a clean, dry area. Store units in an upright position at all times. Stack units a maximum of 3 units high.

Unit Protection

Cover units on the job site with either the original packaging or an equivalent protective covering. Cap the open ends of pipes stored on the job site. In areas where painting, plastering, and/or spraying has not been completed, all due precautions must be taken to avoid physical damage to the units and contamination by foreign material. Physical damage and contamination may prevent proper start-up and may result in costly equipment clean-up.

Examine all pipes, fittings, and valves before installing any of the system components. Remove any dirt or debris found in or on these components.

Pre-Installation

Installation, Operation and Maintenance instructions are provided with each unit. Vertical unit configurations are typically installed in a mechanical room. The installation site chosen should include adequate service clearance around the unit. Before unit start-up, read all manuals and become familiar with the unit and its operation. Thoroughly check the system before operation.

Prepare units for installation as follows:

1. Compare the electrical data on the unit nameplate with ordering and shipping information to verify that the correct unit has been shipped.
2. Keep the cabinet covered with the original packaging until installation is complete and all plastering, painting, etc. is finished.
3. Verify refrigerant tubing is free of kinks or dents and that it does not touch other unit components.
4. Inspect all electrical connections. Connections must be clean and tight at the terminals.
5. Remove any blower support packaging.

6. Loosen compressor bolts on units equipped with compressor spring vibration isolation until the compressor rides freely on the springs. Remove shipping restraints.
7. Some airflow patterns are field convertible (horizontal units only). Locate the airflow conversion section of this IOM.
8. Locate and verify any hangers, or other accessory kits located in the compressor section or blower section.

▲ CAUTION! ▲

CAUTION! DO NOT store or install units in corrosive environments or in locations subject to temperature or humidity extremes (e.g., attics, garages, rooftops, etc.). Corrosive conditions and high temperature or humidity can significantly reduce performance, reliability, and service life. Always move units in an upright position. Tilting units on their sides may cause equipment damage.

NOTICE! Failure to remove shipping brackets from spring-mounted compressors will cause excessive noise, and could cause component failure due to added vibration.

▲ CAUTION! ▲

CAUTION! CUT HAZARD - Failure to follow this caution may result in personal injury. Sheet metal parts may have sharp edges or burrs. Use care and wear appropriate protective clothing, safety glasses and gloves when handling parts and servicing heat pumps.

PHYSICAL DATA

Model	024	030	036	042	048	060
Compressor (1 Each)	Copeland UltraTech Two-Stage Scroll					
Factory Charge HFC-410a, oz	51	48	54	70	80	84
ECM Fan Motor & Blower						
Fan Motor, hp [W]	1/2 [373]	1/2 [373]	1/2 [373]	3/4 [559]	3/4 [559]	1 [746]
Blower Wheel Size (Dia x W), in [mm]	9 x 7 [229 x 178]	9 x 7 [229 x 178]	9 x 8 [229 x 203]	9 x 8 [229 x 203]	10 x 10 [254 x 254]	11 x 10 [279 x 254]
Water Connection Size						
Swivel - Residential Class	1"	1"	1"	1"	1"	1"
HWG Water Connection Size						
Swivel - Residential Class	1"	1"	1"	1"	1"	1"
Vertical Upflow						
Air Coil Dimensions (H x W), in [mm]	20 x 17.25 [508 x 438]	20 x 17.25 [508 x 438]	24 x 21.75 [610 x 552]	24 x 21.75 [610 x 552]	28.75 x 24 [730 x 610]	28.75 x 24 [730 x 610]
Standard Filter - 1" [25.4mm] Throw-away, qty (in) [mm]	20 x 20 [508 x 508]	20 x 20 [508 x 508]	24 x 24 [610 x 610]	24 x 24 [610 x 610]	28 x 28 [711 x 711]	28 x 28 [711 x 711]
Weight - Operating, lbs [kg]	216 [98.0]	224 [101.6]	245 [111.1]	260 [117.9]	315 [142.9]	330 [149.7]
Weight - Packaged, lbs [kg]	221 [100.2]	229 [103.9]	251 [113.8]	266 [120.6]	322 [146.0]	337 [152.9]
Horizontal						
Air Coil Dimensions (H x W), in [mm]	16 x 22 [406 x 559]	16 x 22 [406 x 559]	20 x 25 [508 x 635]	20 x 25 [508 x 635]	20 x 35 [508 x 889]	20 x 35 [508 x 889]
Standard Filter - 1" [25.4 mm] Pleated MERV 8 Throwaway, in [mm]	18 x 24 [457 x 610]	18 x 24 [457 x 610]	2 - 14 x 20 [356 x 508]	2 - 14 x 20 [356 x 508]	1 - 20 x 24 [508 x 610] 1 - 14 x 20 [356 x 508]	1 - 20 x 24 [508 x 610] 1 - 14 x 20 [356 x 508]
Weight - Operating, lbs [kg]	208 [94.3]	208 [94.3]	233 [105.6]	244 [110.7]	299 [135.6]	314 [142.4]
Weight - Packaged, lbs [kg]	213 [96.6]	213 [96.6]	239 [108.4]	250 [113.4]	306 [138.8]	321 [145.6]

All units have grommet compressor mountings, TXV expansion devices, and 1/2" [12.7mm] & 3/4" [19.1mm] electrical knockouts.

HE - VERTICAL UPFLOW DIMENSIONAL DATA

Vertical Upflow Model		Overall Cabinet		
		A Width	B Depth	C Height
024-030	in	22.4	22.4	40.5
	cm	56.9	56.9	102.9
036-042	in	22.4	26.0	46.5
	cm	56.9	66.0	118.1
048 -060	in	25.4	29.3	50.5
	cm	64.5	74.4	128.3

Vertical Upflow Model		Water Connections - Standard Units						
		1	2	3	4	5	Loop Water FPT	HWG FPT
		D Loop In	E Loop Out	Cond. F	HWG In G	HWG Out H		
024 - 030	in	3.8	8.8	19.5	13.4	15.7	1	1
	cm	9.6	22.3	49.5	34.0	39.9	2.5	2.5
036 - 042	in	3.8	8.8	22.1	15.2	18.5	1	1
	cm	9.6	22.3	56.1	38.6	47.0	2.5	2.5
048 - 060	in	4.0	9.5	22.1	15.2	18.5	1	1
	cm	10.2	24.1	56.1	38.6	47.0	2.5	2.5

Vertical Model		Electrical Knockouts		
		J 1/2"	K 1/2"	L 3/4"
		Low Voltage	Ext Pump	Power Supply
024 - 060	in	4.6	6.1	7.6
	cm	11.7	15.5	19.3

Notes:

1. While clear access to all removable panels is not required, installer should take care to comply with all building codes and allow adequate clearance for future field service.
2. Front & Side access is preferred for service access. However, all components may be serviced from the front access panel if side access is not available.
3. Discharge flange is field installed.
4. Condensate is 3/4" socket.
5. Source water and optional HWG connections are 1" swivel.

HE - VERTICAL UPFLOW DIMENSIONAL DATA

Vertical Upflow Model		Discharge Connection Duct Flange Installed (+/- 0.10 in, +/- 2.5mm)					Return Connection Standard Deluxe Filter Frame (+/- 0.10 in, +/- 2.5mm)			
		M Left Return	N	O Supply Width	P Supply Depth	Q Right Return	R	S Return Depth	T Return Height	U
024 - 030	in	7.4	4.2	13.9	14.0	6.7	2.2	18.0	18.0	1.0
	cm	18.8	10.7	35.3	35.6	17.0	5.6	45.7	45.7	2.5
036 - 042	in	7.4	6.0	13.9	14.0	7.4	1.4	22.5	22.0	1.0
	cm	18.8	15.2	35.3	35.6	18.8	3.5	57.1	55.9	2.5
048 - 060	in	7.4	6.0	13.9	14.0	8.4	2.8	25.8	26.2	1.0
	cm	18.8	15.2	35.3	35.6	21.3	7.1	65.5	66.4	2.5

Auxiliary Electric Heaters mounted externally.

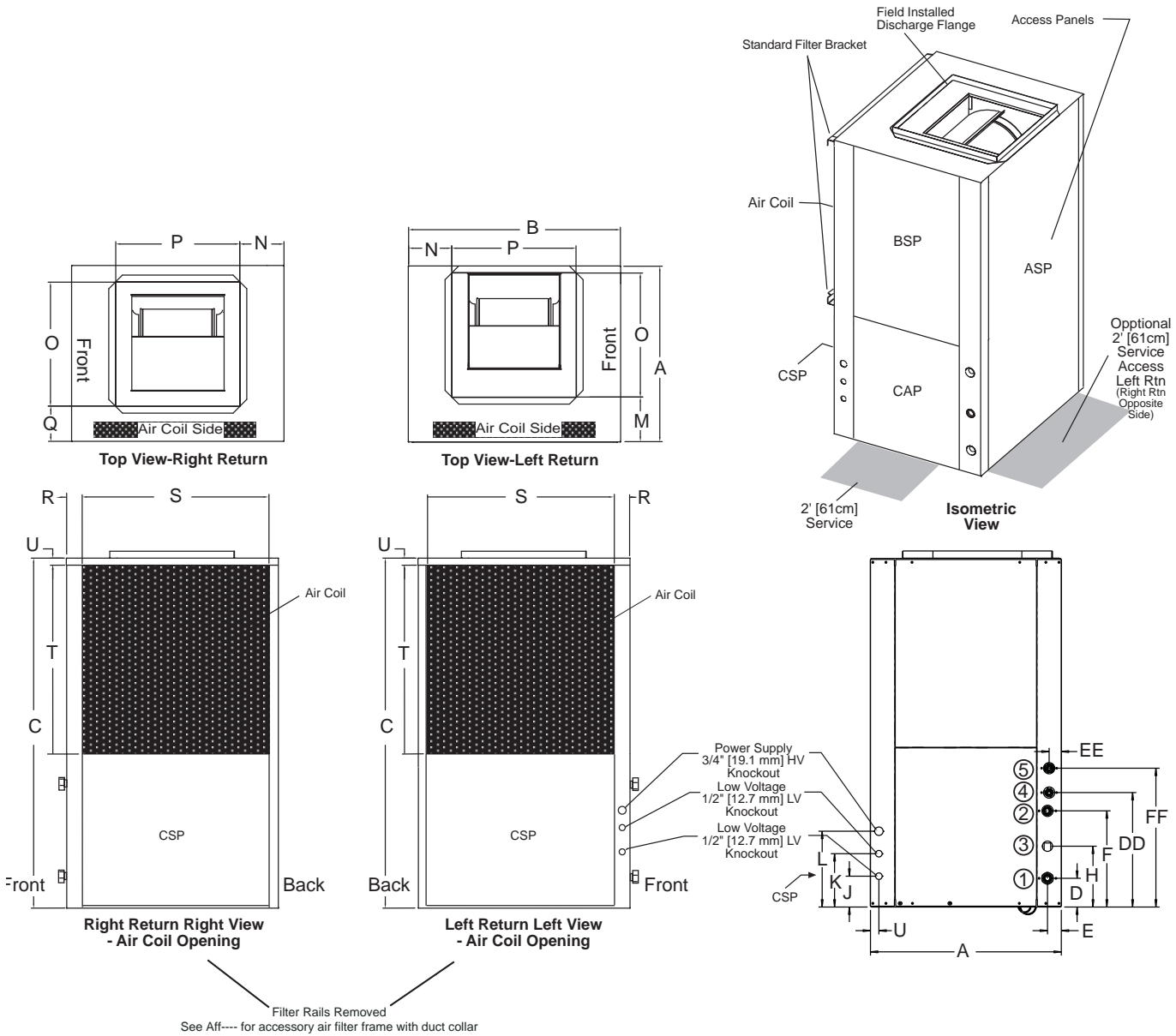

VERTICAL INSTALLATION

Vertical Unit Location

Units are not designed for outdoor installation. Locate the unit in an INDOOR area that allows enough space for service personnel to perform typical maintenance or repairs without removing unit from the mechanical room/closet. Vertical units are typically installed in a mechanical room or closet. Never install units in areas subject to freezing or where humidity levels could cause cabinet condensation (such as unconditioned spaces subject to 100% outside air). Consideration should be given to access for easy removal of the filter and access panels. Provide sufficient room to make water, electrical, and duct connection(s).

If the unit is located in a confined space, such as a closet, provisions must be made for return air to freely enter the space by means of a louvered door, etc. Any access panel screws that would be difficult to remove after the unit is installed should be removed prior to setting the unit. Refer to Figures 7 and 8 for typical installation illustrations. Refer to unit specifications catalog for dimensional data.

1. Install the unit on a piece of rubber, neoprene or other mounting pad material for sound isolation. The pad should be at least 3/8" [10mm] to 1/2" [13mm] in thickness. Extend the pad beyond all four edges of the unit.
2. Provide adequate clearance for filter replacement and drain pan cleaning. Do not block filter access with piping, conduit or other materials. Refer to unit specifications for dimensional data.
3. Provide access for fan and fan motor maintenance and for servicing the compressor and coils without removing the unit.
4. Provide an unobstructed path to the unit within the closet or mechanical room. Space should be sufficient to allow removal of the unit, if necessary.
5. Provide access to water valves and fittings and screwdriver access to the unit side panels, discharge collar and all electrical connections.

The installation of water source heat pump units and all associated components, parts and accessories which make up the installation shall be in accordance with the regulations of ALL authorities having jurisdiction and MUST conform to all applicable codes. It is the responsibility of the installing contractor to determine and comply with ALL applicable codes and regulations.

Figure 7: Vertical Unit Mounting

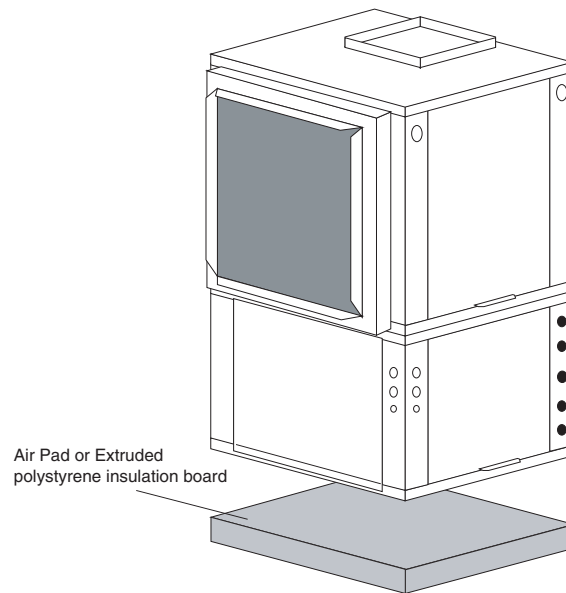
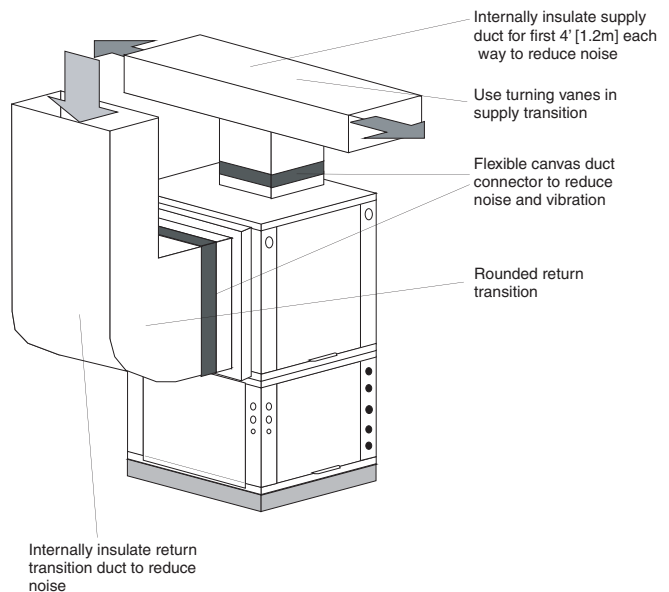

Figure 8: Typical Vertical Unit Installation Using Ducted Return Air



VERTICAL INSTALLATION

Sound Attenuation for Vertical Units

Sound attenuation is achieved by enclosing the unit within a small mechanical room or a closet. Additional measures for sound control include the following:

1. Mount the unit so that the return air inlet is 90° to the return air grille. Refer to Figure 9. Install a sound baffle as illustrated to reduce line-of sight sound transmitted through return air grilles.
2. Mount the unit on a rubber or neoprene isolation pad to minimize vibration transmission to the building structure.

Figure 9: Vertical Sound Attenuation

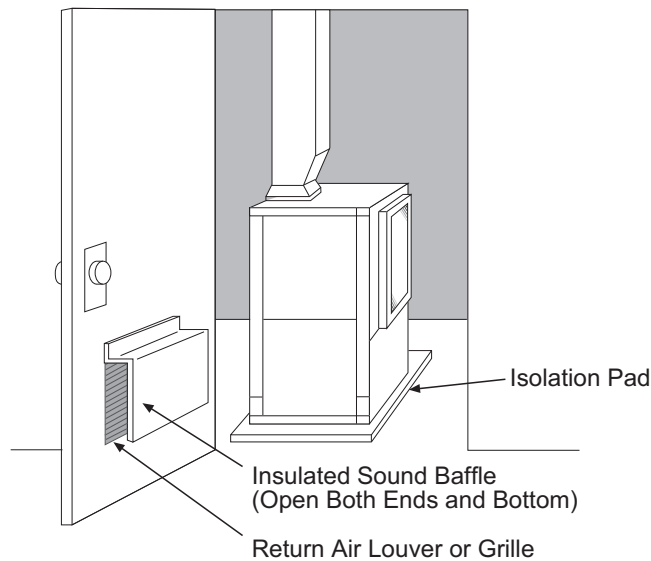

Condensate Piping for Vertical Units

Install condensate trap at each unit with the top of the trap positioned below the unit condensate drain connection as shown in Figure 4. Design the depth of the trap (water-seal) based upon the amount of External Static Pressure (ESP) capability of the blower (where 2 inches [51mm] of ESP capability requires 2 inches [51mm] of trap depth). As a general rule, 1 1/2 inch [38mm] trap depth is the minimum.

Each unit must be installed with its own individual trap and connection to the condensate line (main) or riser. Provide a means to flush or blow out the condensate line. DO NOT install units with a common trap and/or vent.

Always vent the condensate line when dirt or air can collect in the line or a long horizontal drain line is required. Also vent when large units are working against higher external static pressure than other units connected to the same condensate main since this may cause poor drainage for all units on the line. WHEN A VENT IS INSTALLED IN THE DRAIN LINE, IT MUST BE LOCATED AFTER THE TRAP IN THE DIRECTION OF THE CONDENSATE FLOW.

Figure 4: Vertical Condensate Drain

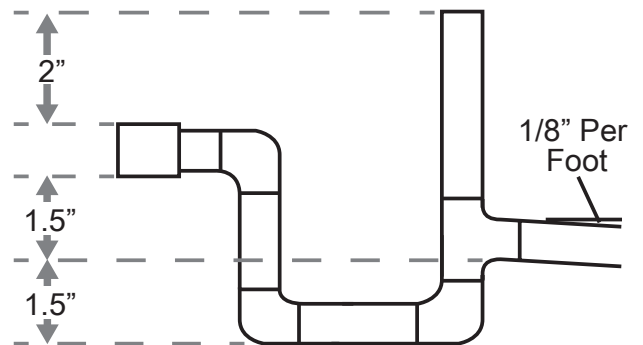

* Some units include a painted drain connection. Using a threaded pipe or similar device to clear any excess paint accumulated inside this fitting may ease final drain line installation.

VERTICAL INSTALLATION

Horizontal Unit Location

Packaged units are not designed for outdoor installation. Locate the unit in an INDOOR area that allows enough space for service personnel to perform typical maintenance or repairs without removing unit from the ceiling. Horizontal units are typically installed above a false ceiling or in a ceiling plenum. Never install units in areas subject to freezing or where humidity levels could cause cabinet condensation (such as unconditioned spaces subject to 100% outside air). Consideration should be given to access for easy removal of the filter and access panels. Provide sufficient room to make water, electrical, and duct connection(s).

If the unit is located in a confined space, such as a closet, provisions must be made for return air to freely enter the space by means of a louvered door or any other method. Any access panel screws that would be difficult to remove after the unit is installed should be removed prior to setting the unit. Refer to Figures 7a and 7b for an illustration of a typical installation. Refer to unit catalog specifications for dimensional data.

Conform to the following guidelines when selecting a unit location:

1. Provide a hinged access door in concealed-spline or plaster ceilings. Provide removable ceiling tiles in T-bar or lay-in ceilings. Refer to horizontal unit dimensions for specific series and model in unit catalog specifications. Size the access opening to accommodate the service technician during the removal or replacement of the compressor and the removal or installation of the unit itself.
2. Provide access to hanger brackets, water valves and fittings. Provide screwdriver clearance to access panels, discharge collars and all electrical connections.
3. DO NOT obstruct the space beneath the unit with piping, electrical cables and other items that prohibit future removal of components or the unit itself.
4. Use a manual portable jack/lift to lift and support the weight of the unit during installation and servicing.

The installation of geothermal heat pump units and all associated components, parts and accessories which make up the GHP system shall be in accordance with the regulations of ALL authorities having jurisdiction and MUST conform to all applicable codes. It is the responsibility of the installing contractor to determine and comply with ALL applicable codes and regulations.

Mounting Horizontal Units

Horizontal units have hanger kits pre-installed from the factory as shown in Figure 5. Figures 7a and 7b shows a typical horizontal unit installation.

Horizontal heat pumps are typically suspended above a ceiling or within a soffit using field supplied, threaded rods sized to support the weight of the unit.

Use four (4) field supplied threaded rods and factory provided vibration isolators to suspend the unit. Hang the unit clear of the floor slab above and support the unit by the mounting bracket assemblies only. DO NOT attach the unit flush with the floor slab above.

Pitch the unit toward the drain as shown in Figure 6 to improve the condensate drainage. On small units (less than 2.5 Tons/8.8 kW) ensure that unit pitch does not cause condensate leaks inside the cabinet.

NOTE: The top panel of a horizontal unit is a structural component. The top panel of a horizontal unit must never be removed from an installed unit unless the unit is properly supported from the bottom. Otherwise, damage to the unit cabinet may occur.

Figure 5: Hanger Bracket

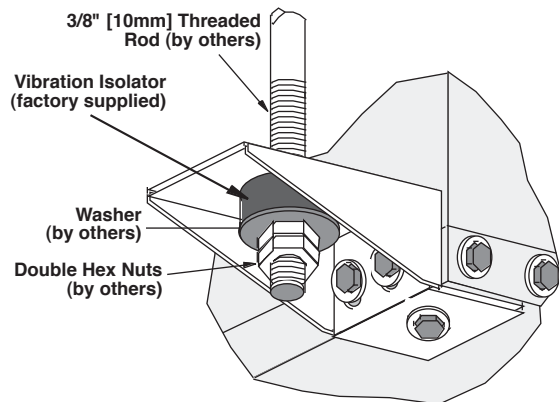
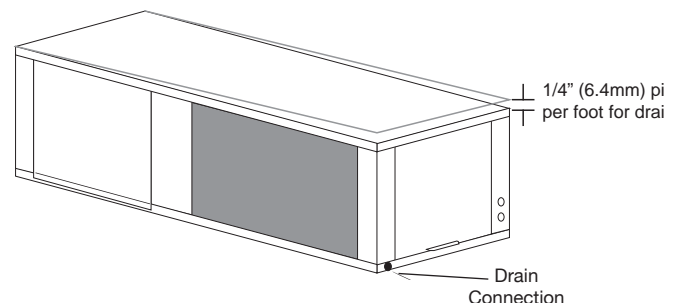
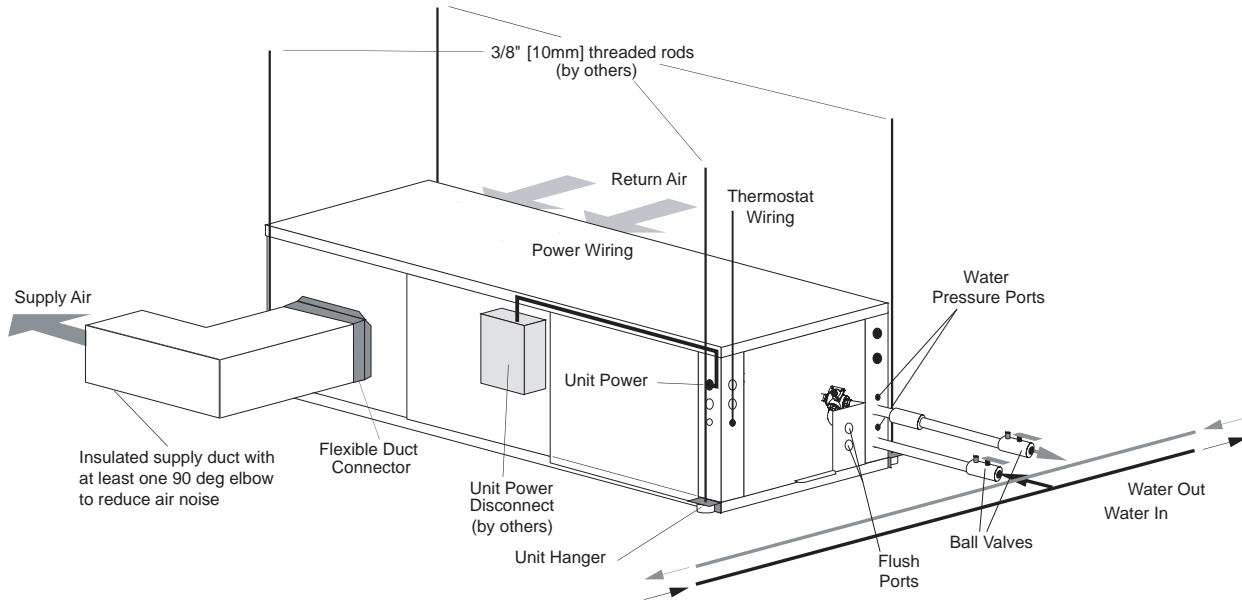

Figure 6: Horizontal Unit Pitch



HORIZONTAL INSTALLATION

Figure 7a: Typical Closed Loop Horizontal Unit Installation



Air Coil - To obtain maximum performance, the air coil should be cleaned before start-up. A 10% solution of dishwasher detergent and water is recommended for both sides of the coil. A thorough water rinse should follow.

Figure 7b: Typical Ground Water Horizontal Unit Installation

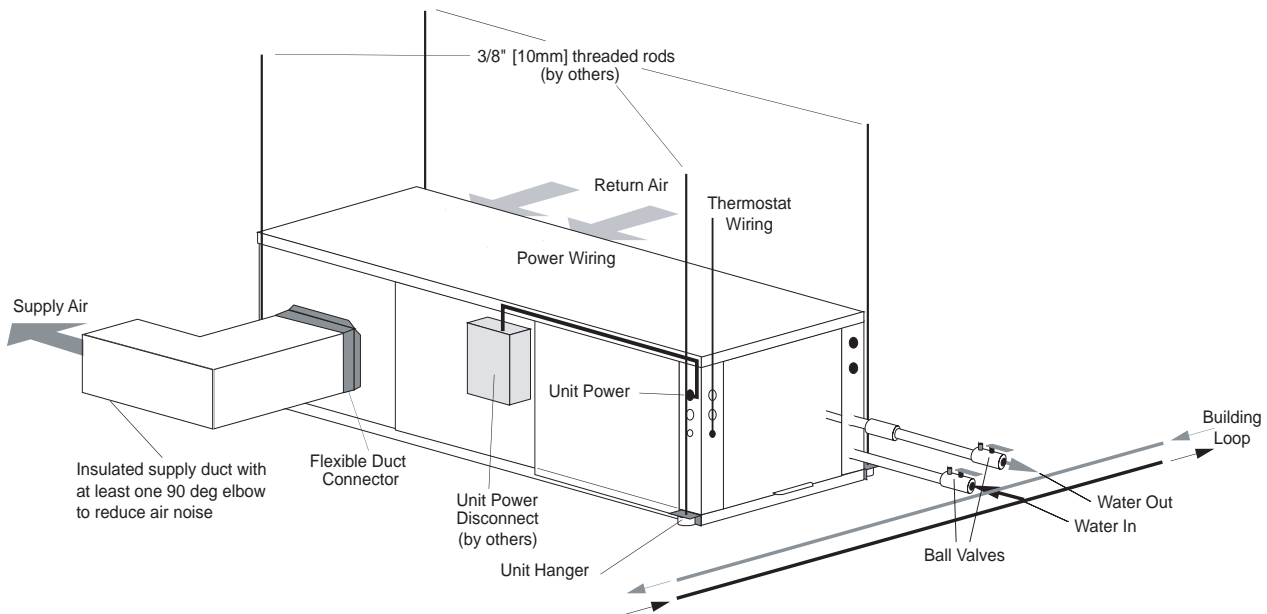

FIELD CONVERSION OF AIR DISCHARGE

Field Conversion of Air Discharge

Overview - Horizontal units can be field converted between side (straight) and back (end) discharge using the instructions below.

Note: It is not possible to field convert return air between left or right return models due to the necessity of refrigeration copper piping changes.

Preparation - It is best to field convert the unit on the ground before hanging. If the unit is already hung it should be taken down for the field conversion.

Side to Back Discharge Conversion

1. Place unit in well lit area. Remove the screws as shown in Figure 8 to free top panel and discharge panel.
2. Lift out the access panel and set aside. Lift and rotate the discharge panel to the other position as shown, being careful with the blower wiring.
3. Check blower wiring and connections for tension or contact with sheet metal edges. Reroute if necessary.
4. Check refrigerant tubing for contact with other components.
5. Reinstall top panel and screws noting that the location for some screws will have changed.
6. Manually spin the fan wheel to ensure that the wheel is not rubbing or obstructed.
7. Replace access panels.

Back to Side Discharge Conversion - If the discharge is changed from back to side, use above instruction noting that illustrations will be reversed.

Left vs. Right Return - It is not possible to field convert return air between left or right return models due to the necessity of refrigeration copper piping changes. However, the conversion process of side to back or back to side discharge for either right or left return configuration is the same. In some cases, it may be possible to rotate the entire unit 180 degrees if the return air connection needs to be on the opposite side. Note that rotating the unit will move the piping to the other end of the unit.

Figure 8: Left Return Side to Back

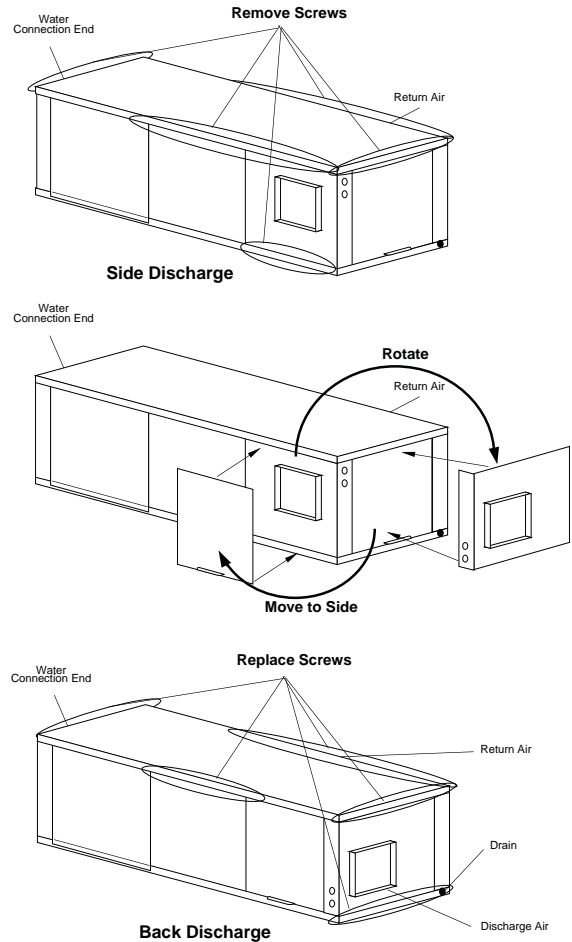
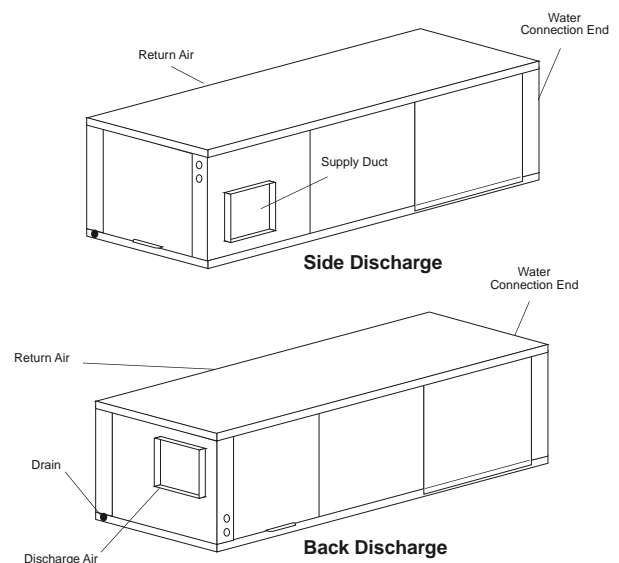

Figure 9: Right Return Side to Back



WATER CONNECTION INSTALLATION

External Flow Controller Mounting

The Flow Controller can be mounted beside the unit as shown in Figure 12. Review the Flow Controller installation manual for more details.

Water Connections-Residential HE Models

Models utilize swivel piping fittings for water connections that are rated for 450 psi (3101 kPa) operating pressure. The connections have a rubber gasket seal similar to a garden hose gasket, which when mated to the flush end of most 1" threaded male pipe fittings provides a leak-free seal without the need for thread sealing tape or joint compound. Insure that the rubber seal is in the swivel connector prior to attempting any connection (rubber seals are shipped attached to the swivel connector). **DO NOT OVER TIGHTEN** or leaks may occur.

The female locking ring is threaded onto the pipe threads

which holds the male pipe end against the rubber gasket, and seals the joint. **HAND TIGHTEN ONLY! DO NOT OVERTIGHTEN!**

Figure 11: Water Connections

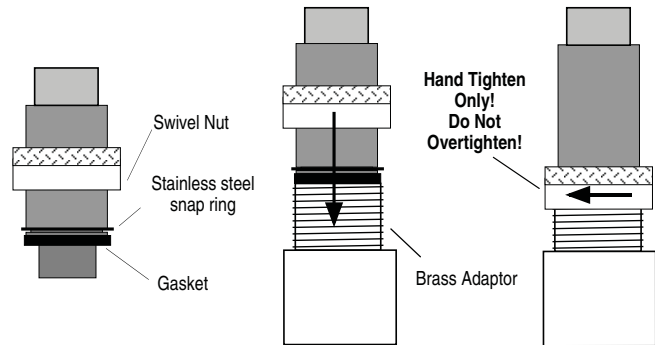

GROUND-LOOP HEAT PUMP APPLICATIONS

▲ CAUTION! ▲

CAUTION! The following instructions represent industry accepted installation practices for closed loop earth coupled heat pump systems. Instructions are provided to assist the contractor in installing trouble free ground loops. These instructions are recommendations only. State/provincial and local codes **MUST** be followed and installation **MUST** conform to **ALL** applicable codes. It is the responsibility of the installing contractor to determine and comply with **ALL** applicable codes and regulations.

Pre-Installation

Prior to installation, locate and mark all existing underground utilities, piping, etc. Install loops for new construction before sidewalks, patios, driveways, and other construction has begun. During construction, accurately mark all ground loop piping on the plot plan as an aid in avoiding potential future damage to the installation.

Piping Installation

The typical closed loop ground source system is shown in Figure 12. All earth loop piping materials should be limited to polyethylene fusion only for in-ground sections of the loop. Galvanized or steel fittings should not be used at any time due to their tendency to corrode. All plastic to metal threaded fittings should be avoided due to their potential to leak in earth coupled applications. A flanged fitting should be substituted. P/T plugs should be used so that flow can be measured using the pressure drop of the unit heat exchanger.

Earth loop temperatures can range between 25 and 110°F [-4 to 43°C]. Flow rates between 2.25 and 3 gpm per ton [2.41 to 3.23 l/m per kW] of cooling capacity recommended in these applications.

Test individual horizontal loop circuits before backfilling. Test vertical U-bends and pond loop assemblies prior to installation. Pressures of at least 100 psi [689 kPa] should be used when testing. Do not exceed the pipe pressure rating. Test entire system when all loops are assembled.

Flushing the Loop

Once piping is completed between the unit, Flow Controller and the ground loop (Figure 12), the loop is ready for final purging and charging. A flush cart with at least a 1.5 hp [1.1 kW] pump is required to achieve enough fluid velocity in the loop piping system to purge air and dirt particles. An antifreeze solution is used in most areas to prevent freezing. All air and debris must be removed from the earth loop piping before operation. Flush the loop with a high volume of water at a minimum velocity of 2 fps (0.6 m/s) in all piping. The steps below must be followed for proper flushing.

1. Fill loop with water from a garden hose through the flush cart before using the flush cart pump to insure an even fill.
2. Once full, the flushing process can begin. Do not allow the water level in the flush cart tank to drop below the pump inlet line to avoid air being pumped back out to the earth loop.
3. Try to maintain a fluid level in the tank above the return tee so that air cannot be continuously mixed back into the fluid. Surges of 50 psi (345 kPa) can be used to help purge air pockets by simply shutting off the return valve going into the flush cart reservoir. This "dead heads" the pump to 50 psi (345 kPa). To purge, dead head the pump until maximum pumping

GROUND-LOOP HEAT PUMP APPLICATIONS

pressure is reached. Open the return valve and a pressure surge will be sent through the loop to help purge air pockets from the piping system.

- Notice the drop in fluid level in the flush cart tank when the return valve is shut off. If air is adequately purged from the system, the level will drop only 1-2 inches (2.5 - 5 cm) in a 10" (25 cm) diameter PVC flush tank (about a half gallon [2.3 liters]), since liquids are incompressible. If the level drops more than this, flushing should continue since air is still being compressed in the loop fluid. Perform the "dead head" procedure a number of times.

Note: This fluid level drop is your only indication of air in the loop.

Antifreeze may be added before, during or after the flushing procedure. However, depending upon which time is chosen, antifreeze could be wasted when emptying the flush cart tank. See antifreeze section for more details.

Loop static pressure will fluctuate with the seasons. Pressures will be higher in the winter months than during the cooling season. This fluctuation is normal and should be considered when charging the system initially. Run the unit in either heating or cooling for a number of minutes to condition the loop to a homogenous temperature. This is a good time for tool cleanup, piping insulation, etc. Then, perform final flush and pressurize the loop to a static pressure of 50-75 psi [345-517 kPa] (winter) or 35-40 psi [241-276 kPa] (summer). After pressurization, be sure to loosen the plug at the end of the Grundfos loop pump motor(s) to allow trapped air to be discharged and to insure the motor housing has been flooded. This is not required for Taco circulators. Insure that the Flow Controller provides adequate flow through the unit by checking pressure drop across the heat exchanger and compare to the pressure drop tables at the back of the manual.

Antifreeze

In areas where minimum entering loop temperatures drop below 40°F [5°C] or where piping will be routed through areas subject to freezing, antifreeze is required. Alcohols and glycols are commonly used as antifreeze; however your local sales manager should be consulted for the antifreeze best suited to your area. Freeze protection should be maintained to 15°F [9°C] below the lowest expected entering loop temperature. For example, if 30°F [-1°C] is the minimum expected entering loop

temperature, the leaving loop temperature would be 25 to 22°F [-4 to -6°C] and freeze protection should be at 15°F [-10°C]. Calculation is as follows:
 $30^{\circ}\text{F} - 15^{\circ}\text{F} = 15^{\circ}\text{F}$ [$-1^{\circ}\text{C} - 9^{\circ}\text{C} = -10^{\circ}\text{C}$].

All alcohols should be premixed and pumped from a reservoir outside of the building when possible or introduced under the water level to prevent fumes. Calculate the total volume of fluid in the piping system. Then use the percentage by volume shown in Table 1 for the amount of antifreeze needed. Antifreeze concentration should be checked from a well mixed sample using a hydrometer to measure specific gravity.

Low Water Temperature Cutout Setting DXM2 Control

When antifreeze is selected, the FP1 jumper (JW3) should be clipped to select the low temperature (antifreeze 13°F [-10.6°C]) set point and avoid nuisance faults (see "Low Water Temperature Cutout Selection" in this manual). NOTE: Low water temperature operation requires extended range equipment.

Table 1: Approximate Fluid Volume (gal.) per 100' of Pipe

Fluid Volume (gal [L]/100' Pipe)		
Pipe	Size	Volume (gal) [L]
Copper	1"	4.1 [15.5]
	1.25"	6.4 [24.2]
	2.5"	9.2 [34.8]
Rubber Hose	1"	3.9 [14.8]
Polyethylene	3/4" IPS SDR11	2.8 [10.6]
	1" IPS SDR11	4.5 [17.0]
	1.25" IPS SDR11	8.0 [30.3]
	1.5" IPS SDR11	10.9 [41.3]
	2" IPS SDR11	18.0 [68.1]
	1.25" IPS SCH40	8.3 [31.4]
	1.5" IPS SCH40	10.9 [41.3]
2" IPS SCH40	17.0 [64.4]	
Unit Heat Exchanger	Typical	1.0 [3.8]
Flush Cart Tank	10" Dia x 3ft [254mm x 0.9m]	10 [37.9]

Table 2: Antifreeze Percentages by Volume

Type	Minimum Temperature for Freeze Protection			
	10°F [-12.2°C]	15°F [-9.4°C]	20°F [-6.7°C]	25°F [-3.9°C]
Methanol	25%	21%	16%	10%
100% USP food grade Propylene Glycol	38%	30%	22%	15%

GROUND-LOOP HEAT PUMP APPLICATIONS

Figure 12: Typical Ground-Loop Application

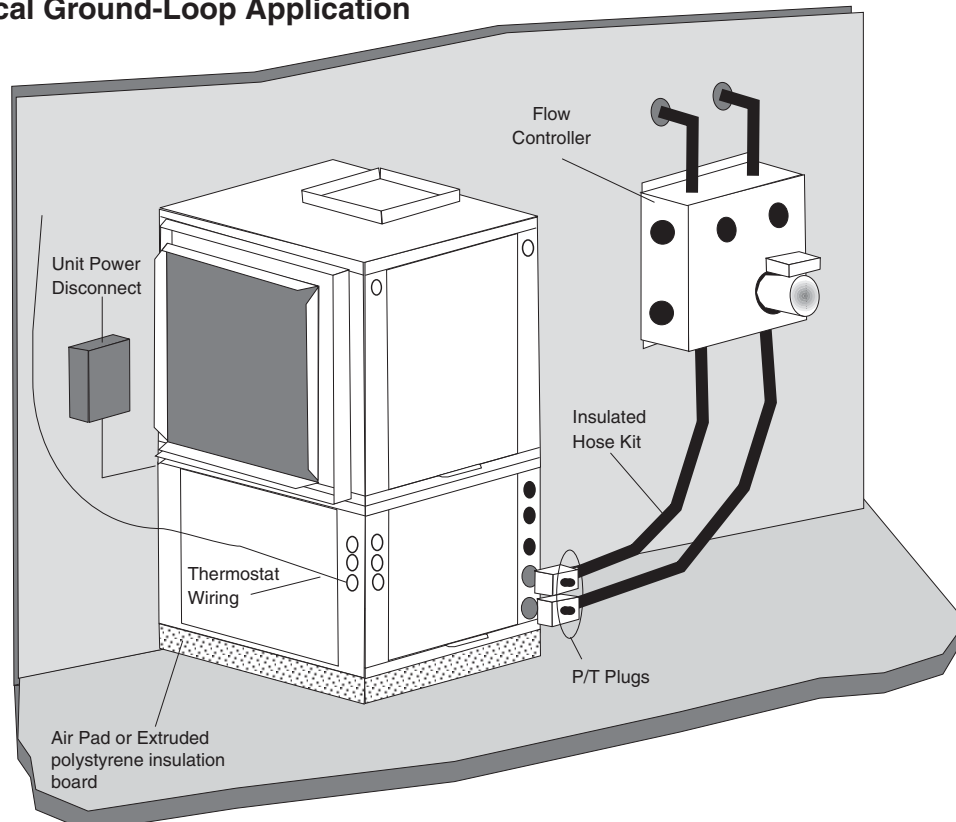

GROUND-WATER HEAT PUMP APPLICATIONS

Open Loop - Ground Water Systems

Typical open loop piping is shown in Figure 13. Shut off valves should be included for ease of servicing. Boiler drains or other valves should be “tee’d” into the lines to allow acid flushing of the heat exchanger. Shut off valves should be positioned to allow flow through the coax via the boiler drains without allowing flow into the piping system. P/T plugs should be used so that pressure drop and temperature can be measured. Piping materials should be limited to copper or PVC SCH80. **Note: Due to the pressure and temperature extremes, PVC SCH40 is not recommended.**

Water quantity should be plentiful and of good quality. Consult table 3 for water quality guidelines. The unit can be ordered with either a copper or cupro-nickel water heat exchanger. Consult Table 3 for recommendations. Copper is recommended for closed loop systems and open loop ground water systems that are not high in mineral content or corrosiveness. In conditions anticipating heavy scale formation or in brackish water, a cupro-nickel heat exchanger is recommended. In ground water situations where scaling could be heavy or where biological growth such as iron bacteria will be present, an open loop system is not recommended. Heat exchanger coils may over time lose heat exchange capabilities due to build up of mineral deposits. Heat exchangers must

only be serviced by a qualified technician, as acid and special pumping equipment is required. Desuperheater coils can likewise become scaled and possibly plugged. In areas with extremely hard water, the owner should be informed that the heat exchanger may require occasional acid flushing. In some cases, the desuperheater option should not be recommended due to hard water conditions and additional maintenance required.

Water Quality Standards

Table 3 should be consulted for water quality requirements. Scaling potential should be assessed using the pH/Calcium hardness method. If the pH <7.5 and the calcium hardness is less than 100 ppm, scaling potential is low. If this method yields numbers out of range of those listed, the Ryznar Stability and Langelier Saturation indices should be calculated. Use the appropriate scaling surface temperature for the application, 150°F [66°C] for direct use (well water/open loop) and desuperheater; 90°F [32°F] for indirect use. A monitoring plan should be implemented in these probable scaling situations. Other water quality issues such as iron fouling, corrosion prevention and erosion and clogging should be referenced in Table 3.

GROUND-WATER HEAT PUMP APPLICATIONS

Expansion Tank and Pump

Use a closed, bladder-type expansion tank to minimize mineral formation due to air exposure. The expansion tank should be sized to provide at least one minute continuous run time of the pump using its drawdown capacity rating to prevent pump short cycling. Discharge water from the unit is not contaminated in any manner and can be disposed of in various ways, depending on local building codes (e.g. recharge well, storm sewer, drain field, adjacent stream or pond, etc.). Most local codes forbid the use of sanitary sewer for disposal. Consult your local building and zoning department to assure compliance in your area.

Water Control Valve

Note the placement of the water control valve in Figure 13. Always maintain water pressure in the heat exchanger by placing the water control valve(s) on the discharge line to prevent mineral precipitation during the off-cycle. Pilot operated slow closing valves are recommended to reduce water hammer. If water hammer persists, a mini-expansion tank can be mounted on the piping to help absorb the excess hammer shock. Insure that the total 'VA' draw of the valve can be supplied by the unit transformer. For instance, a slow closing valve can draw up to 35VA. This can overload smaller 40 or 50 VA transformers depending on the other controls in the circuit. A typical pilot operated solenoid valve draws approximately 15VA.

Flow Regulation

Flow regulation can be accomplished by two methods. One method of flow regulation involves simply adjusting the ball valve or water control valve on the discharge line. Measure the pressure drop through the unit heat exchanger, and determine flow rate from Table 10C. Since the pressure is constantly varying, two pressure gauges may be needed. Adjust the valve until the desired flow of 1.5 to 2 gpm per ton [2.0 to 2.6 l/m per kW] is achieved. A second method of flow control requires a flow control device mounted on the outlet of the water control valve. The device is typically a brass fitting with an orifice of rubber or plastic material that is designed to allow a specified flow rate. On occasion, flow control devices may produce velocity noise that can be reduced by applying some back pressure from the ball valve located on the discharge line. Slightly closing the valve will spread the pressure drop over both devices, lessening the velocity noise. **NOTE: When EWT is below 50°F [10°C], 2 gpm per ton (2.6 l/m per kW) is required.**

Water Coil Low Temperature Limit Setting

For all open loop systems the 30°F [-1.1°C] FP1 setting (factory setting-water) should be used to avoid freeze damage to the unit. See "Low Water Temperature Cutout Selection" in this manual for details on the low limit setting.

Figure 13: Typical Open Loop/Well Application

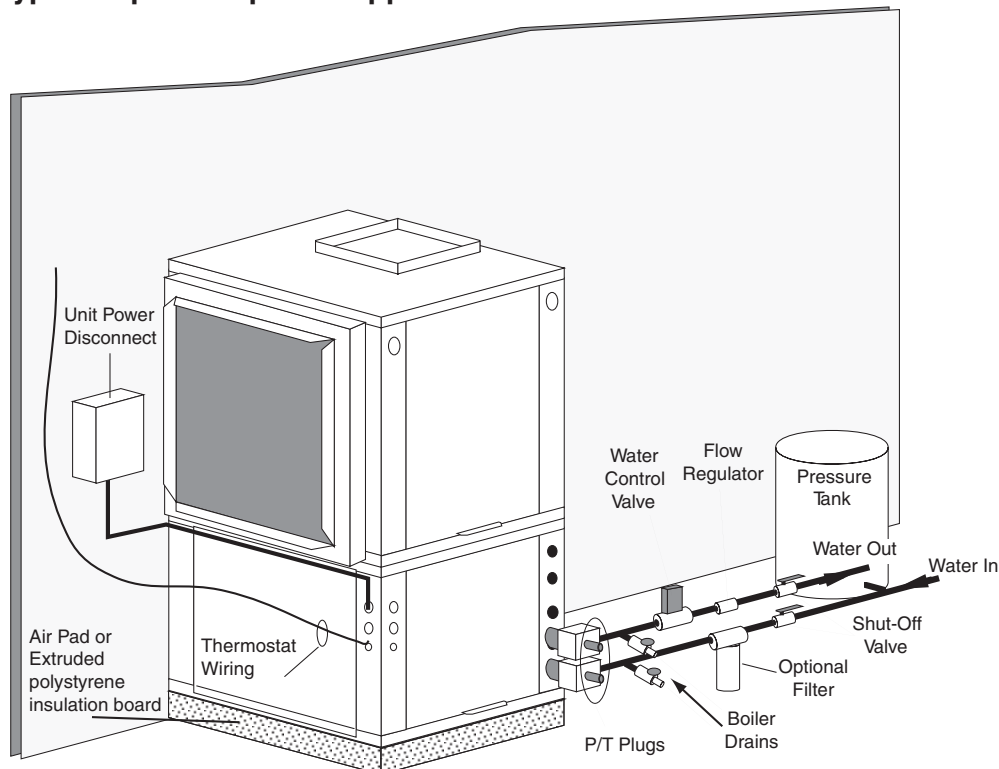

WATER QUALITY STANDARDS

Table 3: Water Quality Standards

Water Quality Parameter	HX Material	Closed Recirculating	Open Loop and Recirculating Well		
Scaling Potential - Primary Measurement					
Above the given limits, scaling is likely to occur. Scaling indexes should be calculated using the limits below					
pH/Calcium Hardness Method	All	-	pH < 7.5 and Ca Hardness <100ppm		
Index Limits for Probable Scaling Situations - (Operation outside these limits is not recommended)					
Scaling indexes should be calculated at 66°C for direct use and HWG applications, and at 32°C for indirect HX use. A monitoring plan should be implemented.					
Ryznar Stability Index	All	-	6.0 - 7.5 If >7.5 minimize steel pipe use.		
Langelier Saturation Index	All	-	-0.5 to +0.5 If <-0.5 minimize steel pipe use. Based upon 66°C HWG and Direct well, 29°C Indirect Well HX		
Iron Fouling					
Iron Fe ²⁺ (Ferrous) (Bacterial Iron potential)	All	-	<0.2 ppm (Ferrous) If Fe ²⁺ (ferrous)>0.2 ppm with pH 6 - 8, O ₂ <5 ppm check for iron bacteria.		
Iron Fouling	All	-	<0.5 ppm of Oxygen Above this level deposition will occur.		
Corrosion Prevention					
pH	All	6 - 8.5 Monitor/treat as needed	6 - 8.5 Minimize steel pipe below 7 and no open tanks with pH <8		
Hydrogen Sulfide (H ₂ S)	All	-	<0.5 ppm At H ₂ S>0.2 ppm, avoid use of copper and copper nickel piping or HX's. Rotten egg smell appears at 0.5 ppm level. Copper alloy (bronze or brass) cast components are OK to <0.5 ppm.		
Ammonia ion as hydroxide, chloride, nitrate and sulfate compounds	All	-	<0.5 ppm		
Maximum Chloride Levels	Maximum Allowable at maximum water temperature.				
			10°C	24°C	38°C
	Copper	-	<20ppm	NR	NR
	Cupronickel	-	<150 ppm	NR	NR
	304 SS	-	<400 ppm	<250 ppm	<150 ppm
316 SS	-	<1000 ppm	<550 ppm	< 375 ppm	
Titanium	-	>1000 ppm	>550 ppm	>375 ppm	
Erosion and Clogging					
Particulate Size and Erosion	All	<10 ppm of particles and a maximum velocity of 1.8 m/s Filtered for maximum 841 micron [0.84 mm, 20 mesh] size.	<10 ppm (<1 ppm "sandfree" for reinjection) of particles and a maximum velocity of 1.8 m/s. Filtered for maximum 841 micron 0.84 mm, 20 mesh] size. Any particulate that is not removed can potentially clog components.		

The ClimateMaster Water Quality Table provides water quality requirements for ClimateMaster coaxial heat exchangers. When water properties are outside of those requirements, an external secondary heat exchanger must be used to isolate the heat pump heat exchanger from the unsuitable water. Failure to do so will void the warranty for the coaxial heat exchanger.

Rev.: 3/22/2012

- Notes:
- Closed Recirculating system is identified by a closed pressurized piping system.
 - Recirculating open wells should observe the open recirculating design considerations.
 - NR - Application not recommended.
 - "-" No design Maximum.

HOT WATER GENERATOR

The HWG (Hot Water Generator) or desuperheater option provides considerable operating cost savings by utilizing heat energy from the compressor discharge line to help satisfy domestic hot water requirements. The HWG is active throughout the year, providing virtually free hot water when the heat pump operates in the cooling mode or hot water at the COP of the heat pump during operation in the heating mode.

Heat pumps equipped with the HWG option include a built-in water to refrigerant heat exchanger that eliminates the need to tie into the heat pump refrigerant circuit in the field. The control circuit and pump are also built in for residential equipment. Figure 14 shows a typical example of HWG water piping connections on a unit with built-in circulating pump. This piping layout prevents sludge/debris from the bottom of the tank being pulled into the HWG pump.

The temperature set point of the HWG is field selectable to 125°F or 150°F. The 150°F set point allows more heat storage from the HWG. For example, consider the amount of heat that can be stored by the HWG when using the 125°F set point, versus the amount of heat that can be generated by the HWG when using the 150°F set point.

In a typical 50 gallon two-element electric water heater the lower element should be turned down to 100°F, or the lowest setting, to get the most from the HWG. The tank will eventually stratify so that the lower 80% of the tank, or 40 gallons, becomes 100°F (controlled by the lower element). The upper 20% of the tank, or 10 gallons, will be maintained at 125°F (controlled by the upper element).

Using a 125°F set point, the HWG can heat the lower 40 gallons of water from 100°F to 125°F, providing up to 8,330 btu's of heat. Using the 150°F set point, the HWG can heat the same 40 gallons of water from 100°F to 150°F and the remaining 10 gallons of water from 125°F to 150°F, providing a total of up to 18,743 btu's of heat, or more than twice as much heat as when using the 125°F set point.

Dual element electric water heaters are recommended. If a gas, propane, oil or electric water heater with a single element is used, a second preheat storage tank is recommended to insure a usable entering water temperature for the HWG.

Typically a single tank of at least 50 gallons (189 liters) is used to limit installation costs and space. However, a dual tank, as shown in Figure 21, is the preferred system, as it provides the maximum storage and temperate source water to the HWG.

It is always advisable to use water softening equipment on domestic water systems to reduce the scaling potential and lengthen equipment life. In extreme water conditions, it may be necessary to avoid the use of the HWG option since the potential cost of frequent maintenance may offset or exceed any savings. Consult Table 3 for scaling potential tests.

Figure 14: Typical HWG Installation

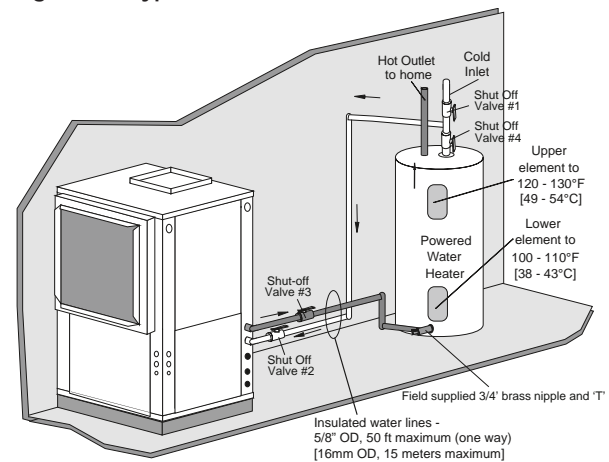
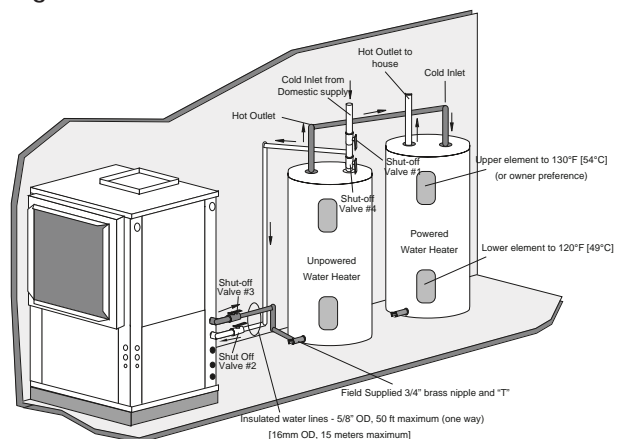

Figure 15: HWG Double Tank Installation



▲ WARNING! ▲

WARNING! A 150°F SETPOINT MAY LEAD TO SCALDING OR BURNS. THE 150°F SET POINT MUST ONLY BE USED ON SYSTEMS THAT EMPLOY AN APPROVED ANTI-SCALD VALVE.

HOT WATER GENERATOR

Installation

The HWG is controlled by two sensors and the DXM2 micro-processor control. One sensor is located on the compressor discharge line to sense the discharge refrigerant temperature. The other sensor is located on the HWG heat exchanger's "Water In" line to sense the potable water temperature.

⚠ WARNING! ⚠

WARNING! UNDER NO CIRCUMSTANCES SHOULD THE SENSORS BE DISCONNECTED OR REMOVED. FULL LOAD CONDITIONS CAN DRIVE HOT WATER TANK TEMPERATURES FAR ABOVE SAFE TEMPERATURE LEVELS IF SENSORS DISCONNECTED OR REMOVED.

The microprocessor control monitors the refrigerant and water temperatures to determine when to operate the HWG. The HWG will operate any time the refrigerant temperature is sufficiently above the water temperature. Once the HWG has satisfied the water heating demand during a heat pump run cycle, the controller will cycle the pump at regular intervals to determine if an additional HWG cycle can be utilized. The microprocessor control includes 3 DIP switches, SW10 (HWG PUMP TEST), SW11 (HWG TEMP), and SW12 (HWG STATUS).

SW10 HWG PUMP TEST. When this switch is in the "ON" position, the HWG pump is forced to operate even if there is no call for the HWG. This mode may be beneficial to assist in purging the system of air during initial start up. When SW10 is in the "OFF" position, the HWG will operate normally. This switch is shipped from the factory in the "OFF" (normal) position. **NOTE:** If left in the "On" position for 5 minutes, the pump control will revert to normal operation.

SW11 HWG TEMP. The control setpoint of the HWG can be set to either of two temperatures, 125°F or 150°F. When SW11 is in the "ON" position the HWG setpoint is 150°F. When SW11 is in the "OFF" position the HWG setpoint is

⚠ WARNING! ⚠

WARNING! USING A 150°F SETPOINT ON THE HWG WILL RESULT IN WATER TEMPERATURES SUFFICIENT TO CAUSE SEVERE PHYSICAL INJURY IN THE FORM OF SCALDING OR BURNS, EVEN WHEN THE HOT WATER TANK TEMPERATURE SETTING IS VISIBLY SET BELOW 150°F. THE 150°F HWG SETPOINT MUST ONLY BE USED ON SYSTEMS THAT EMPLOY AN APPROVED ANTI-SCALD VALVE (PART NUMBER AVAS4) AT THE HOT WATER STORAGE TANK WITH SUCH VALVE PROPERLY SET TO CONTROL WATER TEMPERATURES DISTRIBUTED TO ALL HOT WATER OUTLETS AT A TEMPERATURE LEVEL THAT PREVENTS SCALDING OR BURNS!

ANTI-SCALD VALVE PIPING CONNECTIONS

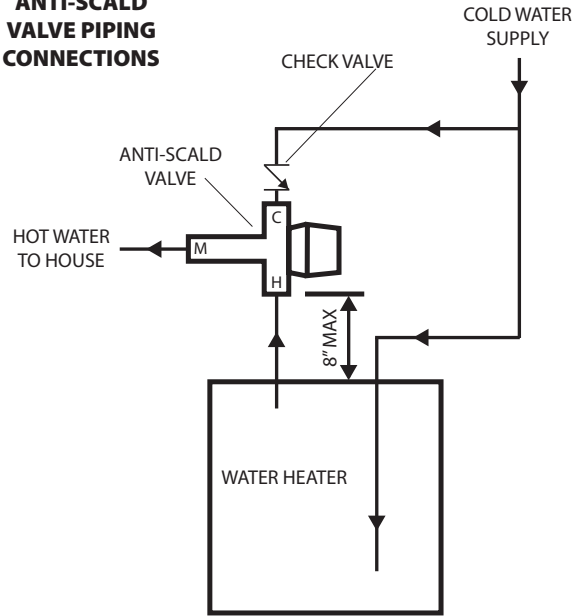

125°F. This switch is shipped from the factory in the "OFF" (125°F) position.

SW12 HWG STATUS. This switch controls operation of the HWG. When SW12 is in the "ON" position the HWG is disabled and will not operate. When SW12 is in the "OFF" position the HWG is in the enabled mode and will operate normally. This switch is shipped from the factory in the "ON" (disabled) position.

CAUTION: DO NOT PLACE THIS SWITCH IN THE ENABLED POSITION UNTIL THE HWG PIPING IS CONNECTED, FILLED WITH WATER, AND PURGED OR PUMP DAMAGE WILL OCCUR.

When the control is powered and the HWG pump output is not active, the status LED (AN1) will be "On". When the HWG pump output is active for water temperature sampling or HWG operation, the status LED will slowly flash (On 1 second, Off 1 second).

If the control has detected a fault, the status LED will flash a numeric fault code as follows:

Hot Water Sensor Fault	1 flash
Compressor Discharge sensor fault	2 flashes
High Water Temperature (>160oF)	3 flashes
Control Logic Error	4 flashes

Fault code flashes have a duration of 0.4 seconds with a 3 second pause between fault codes. For example, a "Compressor Discharge sensor fault" will be four flashes 0.4 seconds long, then a 3 second pause, then four flashes again, etc.

HOT WATER GENERATOR

⚠ WARNING! ⚠

WARNING! The HWG pump is fully wired from the factory. Use extreme caution when working around the microprocessor control as it contains line voltage connections that presents a shock hazard that can cause severe injury or death!

The heat pump, water piping, pump, and hot water tank should be located where the ambient temperature does not fall below 50°F [10°C]. Keep water piping lengths at a minimum. DO NOT use a one way length greater than 50 ft. (one way) [15 m]. See Table 4 for recommended piping sizes and maximum lengths.

All installations must be in accordance with local codes. The installer is responsible for knowing the local requirements, and for performing the installation accordingly. DO NOT activate the HWG (turn DIP 3-4 to the ON position) until "Initial Start-Up" section, below is completed. Powering the pump before all installation steps are completed will damage the pump.

Water Tank Preparation

1. Turn off power or fuel supply to the hot water tank.
2. Connect a hose to the drain valve on the water tank.
3. Shut off the cold water supply to the water tank.
4. Open the drain valve and open the pressure relief valve or a hot water faucet to drain tank.
5. When using an existing tank, it should be flushed with cold water after it is drained until the water leaving the drain hose is clear and free of sediment.
6. Close all valves and remove the drain hose.
7. Install HWG water piping.

HWG Water Piping

1. Using at least 1/2" [12.7mm] I.D. copper, route and install the water piping and valves as shown in Figures 20 or 21. Install an approved anti-scald valve if the 150°F HWG setpoint is or will be selected. An appropriate method must be employed to purge air from the HWG piping. This may be accomplished by flushing water through the HWG (as in Figures 20 and 21) or by installing an air vent at the high point of the HWG piping system.
2. Insulate all HWG water piping with no less than 3/8" [10mm] wall closed cell insulation.
3. Open both shut off valves and make sure the tank drain valve is closed.

Water Tank Refill

1. Close valve #4. Ensure that the HWG valves (valves #2 and #3) are open. Open the cold water supply (valve #1) to fill the tank through the HWG piping. This will force water flow through the HWG and purge air from the HWG piping.
2. Open a hot water faucet to vent air from the system until water flows from faucet; turn off faucet. Open valve #4.
3. Depress the hot water tank pressure relief valve handle to

ensure that there is no air remaining in the tank.

4. Inspect all work for leaks.
5. Before restoring power or fuel supply to the water heater, adjust the temperature setting on the tank thermostat(s) to insure maximum utilization of the heat available from the refrigeration system and conserve the most energy. On tanks with both upper and lower elements and thermostats, the lower element should be turned down to 100°F [38°C] or the lowest setting; the upper element should be adjusted to 120-130°F [49-54°C]. Depending upon the specific needs of the customer, you may want to adjust the upper element differently. On tanks with a single thermostat, a preheat tank should be used (Fig 21).
6. Replace access cover(s) and restore power or fuel supply.

Initial Start-Up

1. Make sure all valves in the HWG water circuit are fully open.
2. Turn on the heat pump and allow it to run for 10-15 minutes.
3. Set S3-4 to the "ON" position (enabled) to engage the HWG. See Figure *.
4. The HWG pump should not run if the compressor is not running.
5. The temperature difference between the water entering and leaving the HWG coil should be approximately 5-10°F [3-6°C].
6. Allow the unit to operate for 20 to 30 minutes to insure that it is functioning properly.

ELECTRICAL - LINE VOLTAGE

⚠ WARNING! ⚠

WARNING! To avoid possible injury or death due to electrical shock, open the power supply disconnect switch and secure it in an open position during installation.

⚠ CAUTION! ⚠

CAUTION! Use only copper conductors for field installed electrical wiring. Unit terminals are not designed to accept other types of conductors.

Electrical - Line Voltage

All field installed wiring, including electrical ground, must comply with the National Electrical Code as well as all applicable local codes. Refer to the unit electrical data for fuse sizes. Consult wiring diagram for field connections that must be made by the installing (or electrical) contractor.

All final electrical connections must be made with a length of flexible conduit to minimize vibration and sound transmission to the building.

General Line Voltage Wiring

Be sure the available power is the same voltage and phase shown on the unit serial plate. Line and low voltage wiring must be done in accordance with local codes or the National Electric Code, whichever is applicable.

Electrical Data -

HE Model	Volt Code	Rated Voltage	Voltage Min/Max	Compressor			HWG Pump FLA	Ext Loop Pump FLA	Fan Motor FLA	Total Unit FLA	Min Circuit Amp	Max Fuse/HACR
				RLA	LRA	Qty						
024	1	208-230/60/1	197/252	11.7	58.3	1	0.5	4.0	3.9	20.1	23.0	30
030	1	208-230/60/1	197/252	13.1	73.0	1	0.5	4.0	3.9	21.5	24.7	35
036	1	208-230/60/1	197/252	15.3	83.0	1	0.5	4.0	3.9	23.7	27.5	40
042	1	208-230/60/1	197/252	17.9	96.0	1	0.5	4.0	5.2	27.6	32.0	45
048	1	208-230/60/1	197/252	21.2	104.0	1	0.5	4.0	5.2	30.9	36.2	50
060	1	208-230/60/1	197/252	27.1	152.9	1	0.5	4.0	6.9	38.5	45.2	70

HACR circuit break in U.S. only
All fuses Class RK-5

Wire length based on one way measurement with 2% voltage drop
Wire sizes based on 140°F (60°C) copper conductor

ELECTRICAL - POWER WIRING

Power Connection

Line voltage connection is made by connecting the incoming line voltage wires to the "L" side of the contactor as shown in Figures 18. Consult Table 4 for correct fuse size.

208 Volt Operation

All residential 208-230 Volt units are factory wired for 230 Volt operation. The transformer may be switched to the 208V tap as illustrated on the wiring diagram by switching the red (208V) and the orange (230V) wires at

Figure 18: HE Single Phase Line Voltage Field Wiring

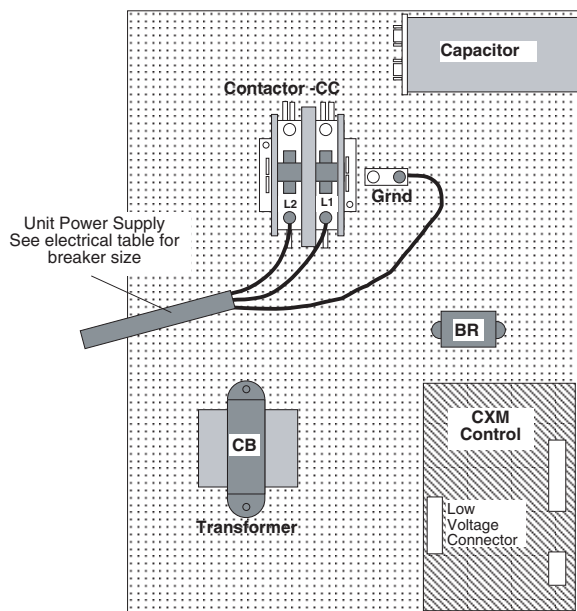

Blower Speed Selection

PSC (Permanent Split Capacitor) blower fan speed can be changed by moving the blue wire on the fan motor terminal block to the desired speed as shown in Figure 19. Units are shipped on the medium speed tap. Consult engineering design guide for specific unit airflow tables. Typical unit design delivers rated airflow at nominal static (0.15 in. w.g. [37Pa]) on medium speed and rated airflow at a higher static (0.4 to 0.5 in. w.g. [100 to 125 Pa]) on high speed for applications where higher static is required. Low speed will deliver approximately 85% of rated airflow at 0.10 in. w.g. [25 Pa].

Special Note for AHRI Testing: To achieve rated airflow for AHRI testing purposes on all PSC products, it is necessary to change the fan speed to "HI" speed. When the heat pump has experienced less than 100 operational hours and the coil has not had sufficient time to be "seasoned", it is necessary to clean the coil with a mild surfactant such as Calgon to remove the oils left by manufacturing processes and enable the condensate to properly "sheet" off of the coil.

Figure 19: PSC Motor Speed Selection

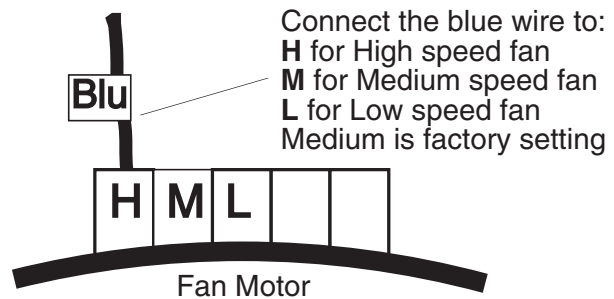

HWG Wiring

The hot water generator pump power wiring is disabled at the factory to prevent operating the HWG pump "dry." After all HWG piping is completed and air purged from the water piping, the pump power wires should be applied to terminals on the HWG power block PB2 as shown in the unit wiring diagram. This connection can also serve as a HWG disable when servicing the unit.

ELECTRICAL - LOW VOLTAGE WIRING

Thermostat Connections

The thermostat should be wired directly to the DXM2 board. See “Electrical – Thermostat” for specific terminal connections.

Figure 21: Low Voltage Field Wiring

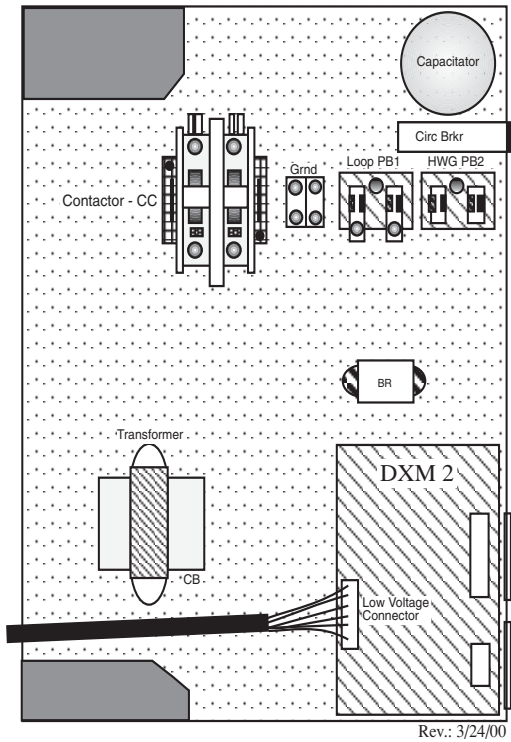

Low Water Temperature Cutout Selection

The DXM2 control allows the field selection of low water (or water-antifreeze solution) temperature limit by clipping jumper JW3, which changes the sensing temperature associated with thermistor LT1. Note that the LT1 thermistor is located on the refrigerant line between the coaxial heat exchanger and expansion device (TXV). Therefore, LT1 is sensing refrigerant temperature, not water temperature, which is a better indication of how water flow rate/temperature is affecting the refrigeration circuit.

The factory setting for LT1 is for systems using water (30°F [-1.1°C] refrigerant temperature). In low water temperature (extended range) applications with antifreeze (most ground loops), jumper JW3 should be clipped as shown in Figure 19 to change the setting to 10°F [-12.2°C] refrigerant temperature, a more suitable temperature when using an antifreeze solution. All residential units include water/refrigerant circuit insulation to prevent internal condensation, which is required when operating with entering water temperatures below 59°F [15°C].

Figure 22: LT1 Limit Setting

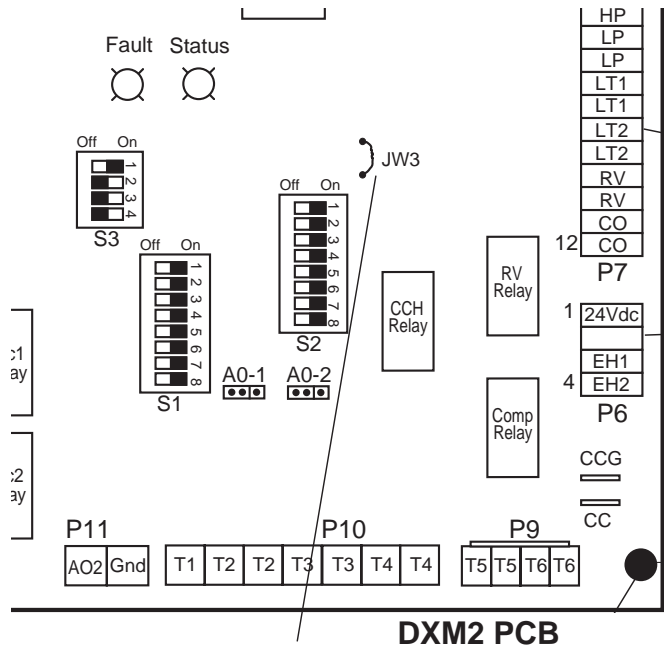

JW3-LT1 jumper should be clipped for low temperature operation

ELECTRICAL - LOW VOLTAGE WIRING

Accessory Connections

A terminal paralleling the compressor contactor coil has been provided on the DXM2 control. Terminal "A" is designed to control accessory devices, such as water valves. Note: This terminal should be used only with 24 Volt signals and not line voltage. Terminal "A" is energized with the compressor contactor. See Figure 23 or the specific unit wiring diagram for details.

Figure 23: Accessory Wiring

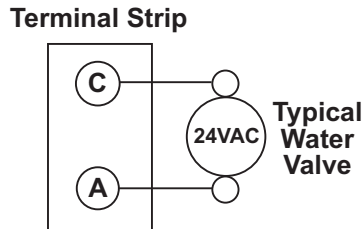

Water Solenoid Valves

An external solenoid valve(s) should be used on ground water installations to shut off flow to the unit when the compressor is not operating. A slow closing valve may be required to help reduce water hammer. Figure 23 shows typical wiring for a 24VAC external solenoid valve. Figures 24 and 25 illustrate typical slow closing water control valve wiring for Taco 500 series and Taco SBV series valves. Slow closing valves take approximately 60 seconds to open (very little water will flow before 45 seconds). Once fully open, an end switch allows the compressor to be energized. Only relay or triac based electronic thermostats should be used with slow closing valves. When wired as shown, the slow closing valve will operate properly with the following notations:

1. The valve will remain open during a unit lockout.
2. The valve will draw approximately 25-35 VA through the "Y" signal of the thermostat.

Note: This valve can overheat the anticipator of an electromechanical thermostat. Therefore, only relay or triac based thermostats should be used.

Figure 24: Taco Series 500 Valve Wiring

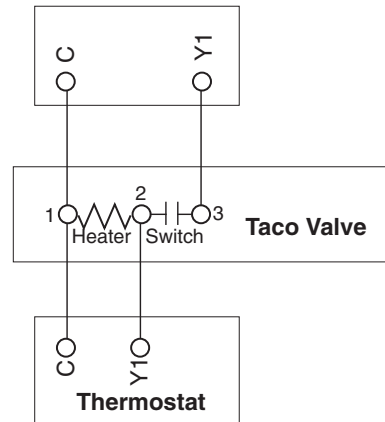
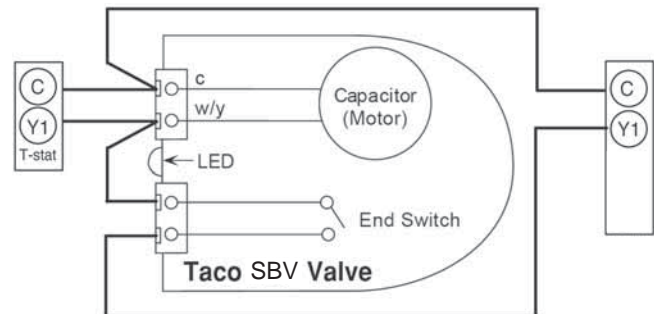

Figure 25: Taco SBV Valve Wiring



ELECTRICAL - THERMOSTAT WIRING

Thermostat Installation

The thermostat should be located on an interior wall in a larger room, away from supply duct drafts. DO NOT locate the thermostat in areas subject to sunlight, drafts or on external walls. The wire access hole behind the thermostat may in certain cases need to be sealed to prevent erroneous temperature measurement. Position the thermostat back plate against the wall so that it appears level and so the thermostat wires protrude through the middle of the back plate. Mark the position of the back plate mounting holes and drill holes with a 3/16" (5mm) bit. Install supplied anchors and secure plate to the wall. Thermostat wire must be 18 AWG wire. Wire the appropriate thermostat as shown in Figures 24a and 24b to the low voltage terminal strip on the DXM2 control board. Practically any heat pump thermostat will work with these units, provided it has the correct number of heating and cooling stages. However, using the communicating thermostat (ATC32) is highly recommended for on-site, easier configuration, monitoring and diagnosis.

Figure 23b: Conventional 3 Heat / 2 Cool Thermostat Connection to DXM2 Control

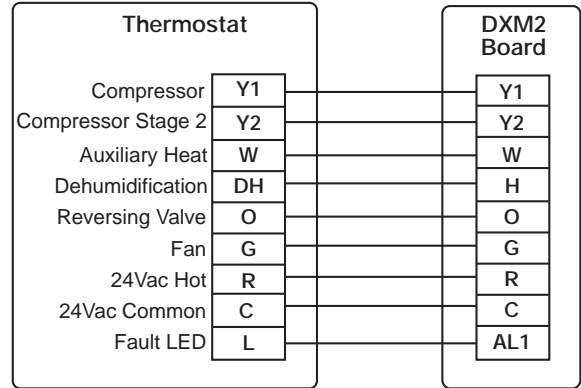

Notes:

- 1) ECM automatic dehumidification mode operates with dehumidification airflows in the cooling mode when the dehumidification output from thermostat is active. Normal heating and cooling airflows are not affected.
- 2) DXM2 board DIP switch S2-7 must be in the auto dehumidification mode for automatic dehumidification
- 3) DH connection not possible with units with internal pump. Use ATC32U**.
- 4) Only use ATC Communicating Thermostat when using Humidifier (H Input) with units with internal flow controller.

Figure 24: Typical Thermostat 2 Heat/1 Cool Connection to DXM2 Control

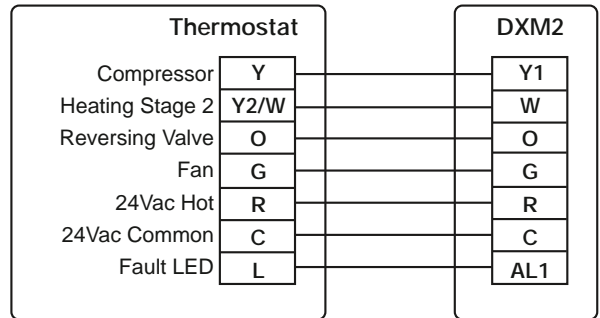

(Using 2 Heat / 1 Cool thermostat is not recommended if maximum efficiency is desired)

⚠ CAUTION! ⚠

CAUTION! Refrigerant pressure activated water regulating valves should never be used with manufacturer's equipment.

Figure 23a: Communicating Thermostat Connection to DXM2 Control

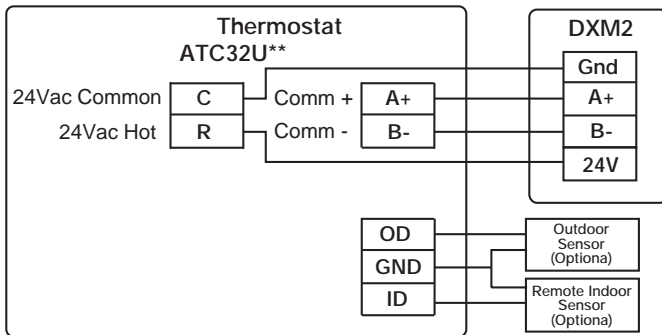

ECM BLOWER CONTROL

The ECM fan is controlled directly by the DXM2 control board that converts thermostat inputs and CFM settings to signals used by the ECM motor controller. To take full advantage of the ECM motor features, a communicating multi-stage thermostat should be used (ATC32U**).

The DXM2 control maintains a selectable operating airflow [CFM] for each heat pump operating mode. For each operating mode there are maximum and minimum airflow limits. See the ECM Blower Performance tables for the maximum, minimum, and default operating airflows.

Airflow levels are selected using the configuration menus of a communicating thermostat (ATC32U**) or diagnostic tool (ACDU**). The configuration menus allow the installer to independently select and adjust the operating airflow for each of the operating modes. Air flow can be selected in 25 CFM increments within the minimum and maximum limits shown in the ECM Blower Performance Table. The blower operating modes include:

- First Stage Cooling (Y1 & O)
- Second Stage Cooling (Y1, Y2, & O)
- First Stage Cooling in Dehumidification Mode (Y1, O, & Dehumid)
- Second Stage Cooling in Dehumidification Mode (Y1, Y2, O, & Dehumid)
- First Stage Heating (Y1)
- Second Stage Heating (Y1 & Y2)
- Third Stage (Auxiliary) Heating (Y1, Y2, & W)
- Emergency Heating (W with no Y1 or Y2)
- Fan (G with no Y1, Y2, or W)

It is highly recommended that ATC32U** or ACDU** be used to set dehumidification mode electronically. For dehumidification settings on other units using the non-communicating stat, refer to DXM2 AOM (part #97B0003N15).

The ECM motor includes “soft start” and “ramp down” features. The soft start feature is a gentle increase of motor rpm at blower start up. This creates a much quieter blower start cycle.

The ramp down feature allows the blower to slowly decrease rpm to a full stop at the end of each blower cycle. This creates a much quieter end to each blower cycle and adds overall unit efficiency.

The ramp down feature is eliminated during an ESD (Emergency Shut Down) situation. When the DXM2 ESD input is activated, the blower and all other control outputs are immediately de-activated.

The ramp down feature (also known as the heating or cooling “Off Delay”) is field selectable by the installer. The allowable range is 0 to 255 seconds.

BLOWER PERFORMANCE DATA

Table 6. ECM Blower Performance Data Table

Model	Max ESP (in. wg)	Fan Motor (hp)	Range	Cooling Mode		Dehumid Mode		Heating Mode		Fan Only Mode	Aux/ Emerg Mode
				Stg 2	Stg 1	Stg 2	Stg 1	Stg 2	Stg 1		
024	0.75	1/2	Default	750	575	650	500	750	575	350	750
			Maximum	850	650	800	600	850	850	850	850
			Minimum	600	450	600	450	600	450	300	650
030	0.5	1/2	Default	950	650	800	575	950	650	450	950
			Maximum	1100	750	1000	700	1100	1100	1100	1100
			Minimum	750	525	750	525	750	525	375	750
036	0.6	1/2	Default	1125	750	975	650	1125	750	525	1125
			Maximum	1250	950	1200	800	1250	1250	1250	1250
			Minimum	900	600	900	600	900	600	450	900
042	0.6	3/4	Default	1300	925	1125	825	1300	925	600	1300
			Maximum	1475	1100	1400	1000	1475	1475	1475	1475
			Minimum	1050	750	1050	750	1050	750	525	1050
048	0.75	3/4	Default	1500	1125	1300	975	1500	1125	700	1500
			Maximum	1700	1300	1600	1200	1700	1700	1700	1700
			Minimum	1200	900	1200	900	1200	900	600	1350
060	0.75	1	Default	1875	1500	1625	1300	1875	1500	875	1875
			Maximum	2100	1700	2000	1600	2100	2100	2100	2100
			Minimum	1500	1200	1500	1200	1500	1200	750	1500

Airflow is controlled within 5% up to the Max ESP shown with wet coil
 Factory shipped on default CFM

DXM2 CONTROLS

DXM2 Control

DXM2 is the next generation in controls is capable of 2-way communication between itself and smart components, like the communicating thermostat, fan motor and configuration/ diagnostic tool.

For most residential applications, configuration, monitoring and diagnostics can be done from the thermostat / service tool and there's no need to read LEDs and change DIP switches.

For details on user settings, refer to User Manual (part #:

For details on Installer settings (not to be used by consumers), refer to Installer manual (part #:

For details on installer/service settings on the configuration/ diagnostic tool, refer to operation manual (part #:

For further details on the DXM2 control, refer to the DXM2 Application, Operation and Maintenance Manual and it is shipped with the unit.

Thermostat compatibility

It is **strongly recommended** that GeoMax2 communicating thermostat be used with DXM2 control, to ensure easy configuration, monitoring and diagnostics, in PLAIN English, on the thermostat. For example, Airflow can NOT be configured without a communicating thermostat or Configuration/ Diagnostic tool for use with GeoMax2.

Field Configuration Options - Note: In the following field configuration options, jumper wires should be clipped **ONLY** when power is removed from the DXM2 control.

Water coil low temperature limit setting: Jumper 3 (JW3-LT1 Low Temp) provides field selection of temperature limit setting for LT1 of 30°F or 10°F [-1°F or -12°C] (refrigerant temperature).

Not Clipped = 30°F [-1°C]. Clipped = 10°F [-12°C].

A0-2: Configure Modulating Valve (field installed accessory)

Set A0-2 jumper to "IOV" if using Modulating Motorized Valve as field installed accessory

DIP Switches – There's no need to change the DIP switches on Residential units. All DIP switches in S1 and S2 should be "on". In S3, S3-1 should be "on" and the rest should be "off". For more details on DIP switches, refer to the DXM2 AOM.

DXM2 Control Start-up Operation

The control will not operate until all inputs and safety controls are checked for normal conditions. The compressor will have a 5 minute anti-short cycle delay at power-up. The first time after power-up that there is a call for compressor, the compressor will follow a 5 to 80 second random start delay. After the random start delay and anti-short cycle delay, the compressor relay will be energized. On all subsequent compressor calls, the random start delay is omitted.

Test Mode button:

Test mode allows the service technician to check the operation of the control in a timely manner. By momentarily pressing the TEST pushbutton, the DXM2 control enters a 20 minute test mode period in which all time delays are sped up 15 times.

Figure 25: Test Mode Button

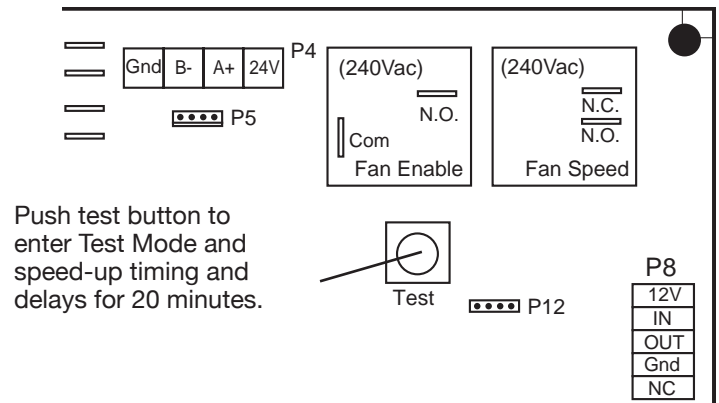

Table 7c: Unit Operation

Conventional T-stat signal (Non-Communicating)	Unit
	ECM fan
G	Fan only
G, Y1	Stage 1 heating ¹
G, Y1, Y2	Stage 2 heating ¹
G, Y1, Y2, W	Stage 3 heating ¹
G, W	Emergency heat
G, Y1, O	Stage 1 cooling ²
G, Y1, Y2, O	Stage 2 cooling ²

- 1 Stage 1 = 1st stage compressor, 1st stage fan operation
Stage 2 = 2nd stage compressor, 2nd stage fan operation
Stage 3 = 2nd stage compressor, auxiliary electric heat, 3rd stage fan operation
- 2 Stage 1 = 1st stage compressor, 1st stage fan operation, reversing valve
Stage 2 = 2nd stage compressor, 2nd stage fan operation, reversing valve

⚠ CAUTION! ⚠

CAUTION! Do not restart units without inspection and remedy of faulting condition. Equipment damage may occur.

DXM2 LAYOUT AND CONNECTIONS

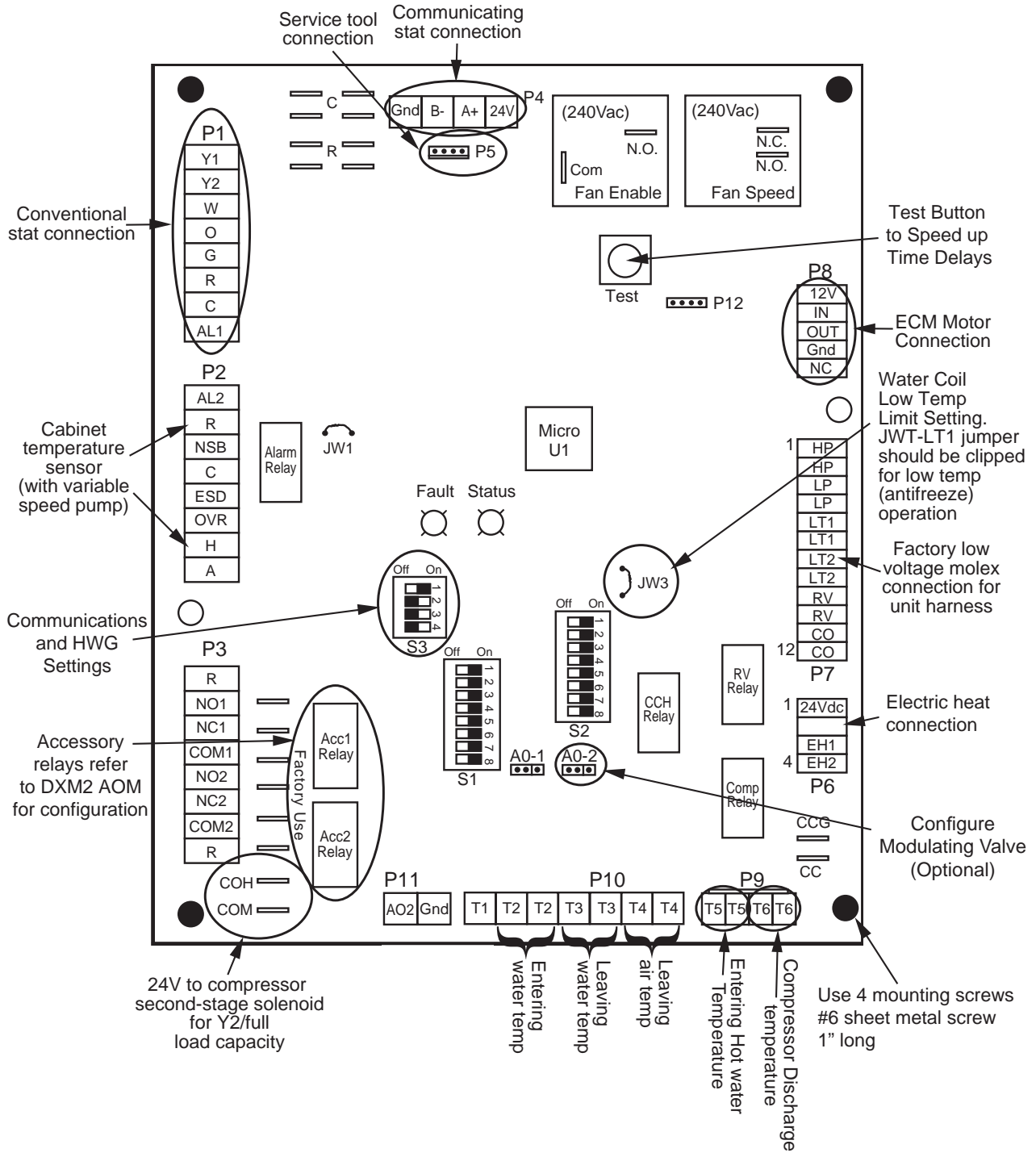

UNIT COMMISSIONING AND OPERATING CONDITIONS

Operating Limits

Environment – Units are designed for indoor installation only. Never install units in areas subject to freezing or where humidity levels could cause cabinet condensation (such as unconditioned spaces subject to 100% outside air).

Power Supply – Voltage utilization shall comply with AHRI standard 110, voltage range A.

Determination of operating limits is dependent primarily upon three factors: 1) return air temperature. 2) water temperature, and 3) ambient temperature. When any one of these factors is at minimum or maximum levels, the other two factors should be at normal levels to insure proper unit operation. Extreme variations in temperature and humidity and/or corrosive water or air will adversely affect unit performance, reliability, and service life. Consult Table 9a for operating limits.

Table 9a: Building Operating Limits

Operating Limits	Unit	
	Cooling	Heating
Air Limits		
Min. ambient air, DB	45°F [7°C]	39°F [4°C]
Rated ambient air, DB	80.6°F [27°C]	68°F [20°C]
Max. ambient air, DB	130°F [54°C]	85°F [29°C]
Min. entering air, DB/WB	65/45°F [18/7°C]	50°F [10°C]
	70/50°F Reheat	
Rated entering air, DB/WB	80.6/66.2°F [27/19°C]	68°F [20°C]
Max. entering air, DB/WB	100/75°F [38/24°C]	80°F [27°C]
Water Limits		
Min. entering water	20°F [-6.7°C]	20°F [-6.7°C]
Normal entering water	50-110°F [10-43°C]	30-70°F [-1 to 21°C]
Max. entering water	120°F [49°C]	120°F [49°C]
Normal Water Flow	1.5 to 3.0 gpm / ton [1.6 to 3.2 l/m per kW]	

Rev.: 4 June, 2012

Commissioning Conditions

Consult Table 9b for commissioning conditions. Starting conditions vary depending upon model and are based upon the following notes:

Notes:

- Conditions in Table 9b are not normal or continuous operating conditions. Minimum/maximum limits are start-up conditions to bring the building space up to occupancy temperatures. Units are not designed to operate under these conditions on a regular basis.
- Voltage utilization complies with AHRI Standard 110, voltage range B.

Table 9b: Building Commissioning Limits

Commissioning Limits	Unit	
	Cooling	Heating
Air Limits		
Min. ambient air, DB	45°F [7°C]	39°F [4°C]
Rated ambient air, DB	80.6°F [27°C]	68°F [20°C]
Max. ambient air, DB	130°F [54°C]	85°F [29°C]
Min. entering air, DB/WB	60°F [16°C]	40°F [4.5°C]
Rated entering air, DB/WB	80.6/66.2°F [27/19°C]	68°F [20°C]
Max. entering air, DB/WB	110/83°F [43/28°C]	80°F [27°C]
Water Limits		
Min. entering water	20°F [-6.7°C]	20°F [-6.7°C]
Normal entering water	50-110°F [10-43°C]	30-70°F [-1 to 21°C]
Max. entering water	120°F [49°C]	120°F [49°C]
Normal Water Flow	1.5 to 3.0 gpm / ton [1.6 to 3.2 l/m per kW]	

Rev.: 4 June, 2012

UNIT STARTING AND OPERATING CONDITIONS

Starting/Commissioning Conditions

Starting conditions are based upon the following notes:

Notes:

1. Conditions in Table 9b are not normal or continuous operating conditions. Minimum/maximum limits are start-up conditions to bring the building space up to occupancy temperatures. Units are not designed to operate under these conditions on a regular basis.
2. Voltage utilization range complies with AHRI Standard 110.

Table 9b: Commissioning Limits

Commissioning Limits	HE Series	
	Cooling	Heating
Air Limits		
Min. ambient air, DB	45°F [7°C]	39°F [4°C]
Rated ambient air, DB	80.6° [27°C]	68° [20°C]
Max. ambient air, DB	110° [43°C]	85° [29°C]
Min. entering air, DB/WB	50/45°F [10/7°C]	40°F [4.5°C]
Rated entering air, DB/WB	80.6/66.2°F [27/19°C]	68°F [20°C]
Max. entering air, DB/WB	110/83°F [43/28°C]	80°F [27°C]
Water Limits		
Min. entering water	30°F [-1°C]	20°F [-6.7°C]
Normal entering water	50-110°F [10-43°C]	30-70°F [-1 to 21°C]
Max. entering water	120°F [49°C]	90°F [32°C]
Normal Water Flow	1.5 to 3.0 gpm/ton [1.6 to 3.2 l/m per KW]	

UNIT START-UP AND OPERATING CONDITIONS

Unit and System Checkout

BEFORE POWERING SYSTEM, please check the following:

UNIT CHECKOUT

- Shutoff valves: Insure that all isolation valves are open.
- Line voltage and wiring: Verify that voltage is within an acceptable range for the unit and wiring and fuses/breakers are properly sized. Verify that low voltage wiring is complete.
- Unit control transformer: Insure that transformer has the properly selected voltage tap. Residential 208-230V units are factory wired for 230V operation unless specified otherwise.
- Loop/water piping is complete and purged of air. Water/piping is clean.
- Antifreeze has been added if necessary.
- Entering water and air: Insure that entering water and air temperatures are within operating limits of Tables 9a and 9b.
- Low water temperature cutout: Verify that low water temperature cut-out on the DXM2 control is properly set.
- Unit fan: Manually rotate fan to verify free rotation and insure that blower wheel is secured to the motor shaft. Be sure to remove any shipping supports if needed. DO NOT oil motors upon start-up. Fan motors are pre-oiled at the factory. Check unit fan speed selection and compare to design requirements.
- Condensate line: Verify that condensate trap is installed and pitched.
- HWG pump is disconnected unless piping is completed and air has been purged from the system.
- Water flow balancing: Record inlet and outlet water temperatures for each heat pump upon startup. This check can eliminate nuisance trip outs and high velocity water flow that could erode heat exchangers.
- Unit air coil and filters: Insure that filter is clean and accessible. Clean air coil of all manufacturing oils.
- Unit controls: Verify that DXM2 field selection options are properly set. Low voltage wiring is complete.
- Blower CFM and Water ΔT is set on communicating thermostats or diagnostic tool.
- Service/access panels are in place.

SYSTEM CHECKOUT

- System water temperature: Check water temperature for proper range and also verify heating and cooling set points for proper operation.
- System pH: Check and adjust water pH if necessary to maintain a level between 6 and 8.5. Proper pH promotes longevity of hoses and fittings (see Table 3).
- System flushing: Verify that all air is purged from the system. Air in the system can cause poor operation or system corrosion. Water used in the system must be potable quality initially and clean of dirt, piping slag, and strong chemical cleaning agents. Some antifreeze solutions may require distilled water.
- Internal Flow Controller: Verify that it is purged of air and in operating condition.
- System controls: Verify that system controls function and

operate in the proper sequence.

- Low water temperature cutout: Verify that low water temperature cut-out controls are set properly (LT1 - JW3).
- Miscellaneous: Note any questionable aspects of the installation.

⚠ CAUTION! ⚠

CAUTION! Verify that ALL water valves are open and allow water flow prior to engaging the compressor. Freezing of the coax or water lines can permanently damage the heat pump.

⚠ CAUTION! ⚠

CAUTION! To avoid equipment damage, DO NOT leave system filled in a building without heat during the winter unless antifreeze is added to the water loop. Heat exchangers never fully drain by themselves and will freeze unless winterized with antifreeze.

Unit Start-up Procedure

1. Turn the thermostat fan position to "ON." Blower should start.
2. Balance air flow at registers.
3. Adjust all valves to their full open position. Turn on the line power to all heat pump units.
4. Room temperature should be within the minimum-maximum ranges of Table 9b. During start-up checks, loop water temperature entering the heat pump should be between 30°F [-1°C] and 95°F [35°C].
5. It is recommended that water-to-air units be first started in the cooling mode, when possible. This will allow liquid refrigerant to flow through the filter-drier before entering the TXV, allowing the filter-drier to catch any debris that might be in the system before it reaches the TXV.
6. Two factors determine the operating limits of geothermal heat pumps, (a) return air temperature, and (b) water temperature. When any one of these factors is at a minimum or maximum level, the other factor must be at normal level to insure proper unit operation.
 - a. Adjust the unit thermostat to the warmest setting. Place the thermostat mode switch in the "COOL" position. Slowly reduce thermostat setting until the compressor activates.
 - b. Check for cool air delivery at the unit grille within a few minutes after the unit has begun to operate. Note: Units have a five minute time delay in the control circuit that can be bypassed on the DXM2 control board as shown below in Figure 25. See controls description for details.
 - c. Verify that the compressor is on and that the water flow rate is correct by measuring pressure drop through the heat exchanger using the pressure ports and comparing to Table 10.
 - d. Check the elevation and cleanliness of the condensate lines. Dripping may be a sign of a blocked line. Check that the condensate trap is filled

UNIT START-UP PROCEDURE

Note: Units have a five minute time delay in the control circuit that can be eliminated on the CXM control board as shown below in Figure 30. See controls description for details.

- c. Verify that the compressor is on and that the water flow rate is correct by measuring pressure drop through the heat exchanger using the P/T plugs and comparing to Table 10C.
 - d. Check the elevation and cleanliness of the condensate lines. Dripping may be a sign of a blocked line. Check that the condensate trap is filled to provide a water seal.
 - e. Refer to Table 9. Check the temperature of both entering and leaving water. If temperature is within range, proceed with the test. If temperature is outside of the operating range, check refrigerant pressures and compare to Tables 10 through 12. Verify correct water flow by comparing unit pressure drop across the heat exchanger versus the data in Table 10C. Heat of rejection (HR) can be calculated and compared to catalog data capacity pages. The formula for HR for systems with water is as follows:

$$HR = TD \times GPM \times 500$$
 where TD is the temperature difference between the entering and leaving water, and GPM is the flow rate in U.S. GPM, determined by comparing the pressure drop across the heat exchanger to Table 10C.
 - f. Check air temperature drop across the air coil when compressor is operating. Air temperature drop should be between 15°F and 25°F [8°C and 14°C].
 - g. Turn thermostat to "OFF" position. A hissing noise indicates proper functioning of the reversing valve.
6. Allow five (5) minutes between tests for pressure to equalize before beginning heating test.
 - a. Adjust the thermostat to the lowest setting. Place the thermostat mode switch in the "HEAT" position.
 - b. Slowly raise the thermostat to a higher temperature until the compressor activates.
 - c. Check for warm air delivery within a few minutes after the unit has begun to operate.
 - d. Refer to Table 9. Check the temperature of both entering and leaving water. If temperature is within range, proceed with the test. If temperature is outside of the operating range, check refrigerant pressures and compare to Table 13. Verify correct water flow by comparing unit pressure drop across the heat exchanger versus the data in Table 10C. Heat of extraction (HE) can be calculated and compared to submittal data capacity pages. The formula for HE for systems with water is as follows:

$$HE = TD \times GPM \times 500$$
 where TD is the temperature difference between the entering and leaving water, and GPM is the flow rate in U.S. GPM, determined by comparing the pressure drop across the heat exchanger to Table 8.
 - e. Check air temperature rise across the air coil when

compressor is operating. Air temperature rise should be between 20°F and 30°F [11°C and 17°C].

- f. Check for vibration, noise, and water leaks.
7. If unit fails to operate, perform troubleshooting analysis (see troubleshooting section). If the check described fails to reveal the problem and the unit still does not operate, contact a trained service technician to insure proper diagnosis and repair of the equipment.
8. When testing is complete, set system to maintain desired comfort level.
9. **BE CERTAIN TO FILL OUT AND FORWARD ALL WARRANTY REGISTRATION PAPERS TO HEAT CONTROLLER.**

⚠ WARNING! ⚠

WARNING! When the disconnect switch is closed, high voltage is present in some areas of the electrical panel. Exercise caution when working with energized equipment.

⚠ CAUTION! ⚠

CAUTION! Verify that ALL water control valves are open and allow water flow prior to engaging the compressor. Freezing of the coax or water lines can permanently damage the heat pump.

Figure 30: Test Mode Pins

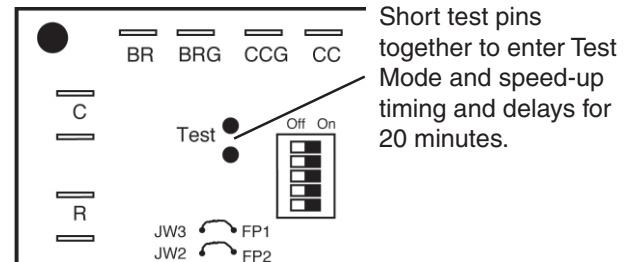

UNIT OPERATING CONDITIONS

Table 10: HE Coax Water Pressure Drop

Model	GPM	Pressure Drop (psi)			
		30°F	50°F	70°F	90°F
024 Rev B	2.5	0.8	0.3	0.2	0.2
	3.0	1.2	0.6	0.5	0.5
	3.8	1.8	1.1	0.9	0.8
	4.5	2.7	1.6	1.2	1.2
	6.0	3.9	2.8	2.2	2.0
030	3.0	1.7	0.9	0.8	0.8
	3.8	2.3	1.2	1.1	1.1
	4.5	2.7	1.6	1.4	1.4
	6.0	3.8	2.4	2.2	2.1
	7.5	5.1	3.5	3.1	2.9
036 Rev B	4.0	0.6	0.1	0.1	0.1
	6.0	1.8	1.0	0.7	0.7
	6.8	2.3	1.5	1.1	1.1
	8.0	3.2	2.2	1.8	1.7
	9.0	4.0	2.9	2.4	2.3
042	3.8	1.7	1.0	0.9	0.9
	5.3	2.7	1.8	1.6	1.5
	7.5	4.5	3.1	2.8	2.6
	7.9	4.8	3.4	3.1	2.9
	10.5	7.4	5.4	4.9	4.7
048	4.5	1.4	1.1	0.9	0.8
	6.0	2.0	1.7	1.4	1.3
	6.8	2.5	2.1	1.8	1.7
	9.0	4.0	3.4	3.0	2.7
	12.0	6.5	5.5	4.9	4.5
060	6.0	4.0	2.6	2.4	2.4
	7.5	5.4	3.8	3.3	3.3
	9.0	6.8	4.9	4.4	4.3
	12.0	10.6	7.9	7.0	6.7
	15.0	16.2	12.8	11.1	10.1

Table 11: Water Temperature Change Through Heat Exchanger

Water Flow, gpm (l/m)	Rise, Cooling °F	Drop, Heating °F
For Closed Loop: Ground Source or Closed Loop Systems at 3 gpm per ton (3.9 l/m per kw)	9 - 12	4 - 8
For Open Loop: Ground Water Systems at 1.5 gpm per ton (2.0 l/m per kw)	20 - 26	10 - 17

Table 12: Antifreeze Correction

Antifreeze Type	Antifreeze %	Cooling			Heating		WPD Corr. Fct. EWT 30°F
		EWT 90°F			EWT 30°F		
		Total Cap	Sens Cap	Power	Htg Cap	Power	
Water	0	1.000	1.000	1.000	1.000	1.000	1.000
Propylene Glycol	5	0.995	0.995	1.003	0.989	0.997	1.070
	15	0.986	0.986	1.009	0.968	0.990	1.210
	25	0.978	0.978	1.014	0.947	0.983	1.360
Methanol	5	0.997	0.997	1.002	0.989	0.997	1.070
	15	0.990	0.990	1.007	0.968	0.990	1.160
	25	0.982	0.982	1.012	0.949	0.984	1.220
Ethanol	5	0.998	0.998	1.002	0.981	0.994	1.140
	15	0.994	0.994	1.005	0.944	0.983	1.300
	25	0.986	0.986	1.009	0.917	0.974	1.360
Ethylene Glycol	5	0.998	0.998	1.002	0.993	0.998	1.040
	15	0.994	0.994	1.004	0.980	0.994	1.120
	25	0.988	0.988	1.008	0.966	0.990	1.200

UNIT OPERATING CONDITIONS

Table 13: HE Series Typical Unit Operating Pressures and Temperatures

024		Full Load Cooling - without HWG active						Full Load Heating - without HWG active					
Entering Water Temp °F	Water Flow GPM/ton	Suction Pressure PSIG	Discharge Pressure PSIG	Superheat	Subcooling	Water Temp Drop °F	Air Temp Drop °F DB	Suction Pressure PSIG	Discharge Pressure PSIG	Superheat	Subcooling	Water Temp Drop °F	Air Temp Rise °F DB
30*	1.5							67-77	297-317	1-6	2-7	8.0-10.0	18-23
	2.25							72-82	303-323	3-8	5-10	5.9-7.9	20-25
	3							77-87	309-329	3-8	5-10	3.8-5.8	21-27
50	1.5	127-137	244-264	8-12	9-14	20.6-22.6	19-25	98-108	340-360	6-11	5-10	11.1-13.1	24-27
	2.25	125-135	205-225	8-12	7-12	14.5-16.5	19-25	104-114	343-363	6-11	5-10	8.1-10.1	26-31
	3	124-134	166-186	10-15	5-10	8.41-10.41	19-25	111-121	346-366	8-12	5-10	5.2-7.2	27-32
70	1.5	132-142	327-347	8-12	11-16	19.9-21.9	18-24	129-139	373-393	10-15	5-10	14.4-16.4	30-35
	2.25	131-141	301-321	8-12	9-14	14.0-16.0	18-24	137-147	390-410	11-16	5-10	10.5-12.5	33-40
	3	130-140	276-296	8-12	7-12	8.0-10.0	18-24	145-155	401-421	11-16	5-10	6.5-8.5	33-36
90	1.5	140-150	457-477	6-11	13-18	19.9-21.9	17-23	162-172	406-426	14-19	3-8	17.5-19.5	36-41
	2.25	139-149	433-453	6-11	11-16	13.2-15.2	17-23	170-180	415-435	14-19	3-8	12.7-14.7	37-41
	3	138-148	409-429	6-11	9-14	7.5-9.5	17-23	178-188	423-443	14-19	3-8	7.9-9.9	38-43
110	1.5	144-154	530-550	4-10	13-18	18.9-20.9	16-22						
	2.25	143-153	510-530	4-10	13-18	13.0-15.0	16-22						
	3	143-153	490-510	4-10	11-16	7.11-9.11	16-22						

*Based on 15% Methanol antifreeze solution

030		Full Load Cooling - without HWG active						Full Load Heating - without HWG active					
Entering Water Temp °F	Water Flow GPM/ton	Suction Pressure PSIG	Discharge Pressure PSIG	Superheat	Subcooling	Water Temp Drop °F	Air Temp Drop °F DB	Suction Pressure PSIG	Discharge Pressure PSIG	Superheat	Subcooling	Water Temp Drop °F	Air Temp Rise °F DB
30*	1.5							65-75	311-331	9-14	9-14	8.0-10.0	19-24
	2.25							67-77	315-335	9-14	9-14	6.2-8.2	20-25
	3							72-82	319-339	9-14	9-14	4.3-6.3	21-26
50	1.5	122-132	240-260	10-15	11-16	19.5-21.5	18-23	95-105	353-373	11-16	10-15	10.5-12.5	26-31
	2.25	121-131	213-233	11-16	9-14	15.0-17.0	19-24	100-110	358-378	11-16	10-15	8.2-10.2	26-31
	3	121-131	186-206	11-16	7-12	10.3-12.3	19-24	105-115	362-382	12-17	10-15	5.8-7.8	27-32
70	1.5	127-137	316-336	9-14	12-17	18.8-20.8	17-22	124-134	390-410	13-18	10-15	13.5-15.5	33-38
	2.25	126-136	298-318	9-14	11-16	14.3-16.3	17-22	130-140	398-418	14-19	9-14	10.5-12.5	33-38
	3	125-135	280-300	9-14	9-14	9.8-11.8	17-22	137-147	405-425	15-20	9-14	7.5-9.5	34-39
90	1.5	133-143	438-458	8-13	14-19	17.8-19.8	15-20	156-166	430-450	16-21	8-13	16.5-18.5	37-42
	2.25	133-143	420-440	8-13	13-18	13.5-15.5	15-20	163-173	459-479	17-22	8-13	12.8-14.8	39-44
	3	132-142	401-421	8-13	11-16	9.2-11.2	15-20	170-180	448-468	18-23	8-13	9.0-11.0	40-45
110	1.5	137-147	507-527	6-11	16-21	17.2-19.2	15-20						
	2.25	136-146	490-510	7-12	14-19	13.0-15.0	15-20						
	3	135-145	473-493	7-12	13-18	8.8-10.8	15-20						

*Based on 15% Methanol antifreeze solution

036		Full Load Cooling - without HWG active						Full Load Heating - without HWG active					
Entering Water Temp °F	Water Flow GPM/ton	Suction Pressure PSIG	Discharge Pressure PSIG	Superheat	Subcooling	Water Temp Drop °F	Air Temp Drop °F DB	Suction Pressure PSIG	Discharge Pressure PSIG	Superheat	Subcooling	Water Temp Drop °F	Air Temp Rise °F DB
30*	1.5							60-70	315-335	4-9	11-16	10.0-12.0	18-23
	2.25							65-75	321-341	5-10	11-16	6.7-8.7	19-24
	3							70-80	327-347	6-11	11-16	3.4-5.4	20-25
50	1.5	123-133	244-264	10-15	12-17	20.9-22.9	17-22	88-98	353-373	6-11	12-17	13.2-15.2	24-29
	2.25	122-132	240-260	10-15	9-14	14.3-16.3	17-22	96-106	361-381	8-13	12-17	9.0-11.0	25-30
	3	121-131	235-255	11-16	7-12	7.8-9.8	17-22	105-115	370-390	9-14	12-17	4.8-6.8	26-31
70	1.5	128-138	328-348	8-13	12-17	20.2-22.2	16-21	116-126	390-410	9-14	12-17	17.0-19.0	29-34
	2.25	124-134	300-320	9-14	10-15	13.8-15.8	16-21	128-138	400-420	11-16	10-15	11.6-13.6	31-36
	3	119-129	273-293	9-14	9-14	7.5-9.5	16-21	139-149	411-431	13-18	10-15	6.1-8.1	32-37
90	1.5	135-145	453-473	7-12	13-18	19.2-21.2	16-21	148-158	424-444	12-17	9-14	20.9-22.9	35-40
	2.25	134-144	428-448	7-12	11-16	13.1-15.1	15-20	160-170	439-459	14-19	9-14	14.2-16.2	37-42
	3	132-142	402-422	8-13	9-14	7.1-9.1	14-19	173-183	453-473	16-21	8-13	7.4-9.4	39-44
110	1.5	139-149	525-545	6-11	14-19	18.5-20.5	13-18						
	2.25	138-148	503-523	6-11	12-17	12.7-14.7	13-18						
	3	137-147	480-500	6-11	10-15	6.9-8.9	14-19						

*Based on 15% Methanol antifreeze solution

UNIT OPERATING CONDITIONS

Table 13: HE Series Typical Unit Operating Pressures and Temperatures: Continued

042		Full Load Cooling - without HWG active						Full Load Heating - without HWG active					
Entering Water Temp °F	Water Flow GPM/ton	Suction Pressure PSIG	Discharge Pressure PSIG	Superheat	Subcooling	Water Temp Rise °F	Air Temp Drop °F DB	Suction Pressure PSIG	Discharge Pressure PSIG	Superheat	Subcooling	Water Temp Drop °F	Air Temp Rise °F DB
30*	1.5							64-74	314-334	6-11	9-14	8.0-10.0	20-25
	2.25							67-77	317-337	6-11	9-14	6.0-8.0	20-25
	3							71-81	321-341	7-12	9-14	4.0-6.0	21-26
50	1.5	121-131	230-250	10-15	10-15	20.5-22.5	22-27	95-105	351-371	8-13	9-14	10.7-12.7	26-31
	2.25	120-130	200-240	11-16	8-13	15.2-17.2	22-27	100-110	356-376	9-14	9-14	8.1-10.1	27-32
	3	120-130	164-184	11-16	6-11	9.8-11.8	22-27	104-114	361-381	10-15	9-14	5.4-7.4	27-32
70	1.5	127-137	305-325	8-13	10-15	19.8-21.8	20-25	124-134	386-406	11-16	8-13	13.8-15.8	32-37
	2.25	125-135	290-310	9-13	9-14	14.7-16.7	21-26	131-141	390-410	12-17	8-13	10.4-12.4	33-37
	3	125-135	263-283	10-15	7-12	9.5-11.5	21-26	138-148	400-420	13-18	7-12	7.0-9.0	34-39
90	1.5	133-143	426-446	7-12	11-16	19-21	19-24	157-167	423-443	13-18	5-10	16.8-18.8	38-43
	2.25	132-142	406-426	7-12	9-14	14-16	19-24	164-174	432-452	15-20	5-10	12.7-14.7	40-45
	3	132-142	390-410	7-12	8-13	9-11	19-24	172-182	441-461	16-21	5-10	8.5-10.5	41-46
110	1.5	137-147	494-514	5-10	11-16	18-20	18-23						
	2.25	136-146	477-497	6-11	10-15	14-16	18-23						
	3	136-146	460-480	6-11	8-13	9-11	18-23						

*Based on 15% Methanol antifreeze solution

048		Full Load Cooling - without HWG active						Full Load Heating - without HWG active					
Entering Water Temp °F	Water Flow GPM/ton	Suction Pressure PSIG	Discharge Pressure PSIG	Superheat	Subcooling	Water Temp Drop °F	Air Temp Drop °F DB	Suction Pressure PSIG	Discharge Pressure PSIG	Superheat	Subcooling	Water Temp Drop °F	Air Temp Rise °F DB
30*	1.5							61-71	290-310	9-14	5-10	7.7-9.7	18-23
	2.25							64-74	293-313	9-14	5-10	5.7-7.7	18-23
	3							68-78	296-316	10-15	5-10	3.7-5.7	18-23
50	1.5	124-134	250-270	11-16	13-18	20.1-22.1	19-24	88-98	319-339	11-16	6-11	10.3-12.3	24-29
	2.25	123-133	212-232	12-17	10-15	14.8-16.8	19-24	94-104	324-344	11-16	6-11	7.8-9.8	25-30
	3	121-131	173-193	13-18	7-12	9.5-11.5	19-24	100-110	330-350	12-17	6-11	5.3-7.3	25-30
70	1.5	129-139	334-354	9-14	16-21	19.6-21.6	18-23	117-127	349-369	13-18	5-10	13.4-15.4	29-34
	2.25	128-138	309-329	10-15	13-18	14.4-16.4	18-23	125-135	357-377	14-19	5-10	10.2-12.2	30-35
	3	127-137	284-304	10-15	10-15	9.3-11.3	18-23	133-143	365-385	15-20	4-11	6.9-8.9	31-36
90	1.5	135-145	470-490	7-12	20-25	18.9-20.9	16-21	150-160	384-404	15-20	3-8	16.6-18.6	35-40
	2.25	134-144	446-466	7-12	17-22	13.8-15.8	16-21	158-168	391-411	16-21	2-7	12.6-14.6	36-41
	3	132-142	422-442	8-13	15-20	8.8-10.8	16-21	166-176	399-419	17-22	2-7	8.5-10.5	37-42
110	1.5	138-148	548-568	6-11	22-27	18.6-20.6	15-20						
	2.25	138-148	526-546	6-11	19-24	13.6-15.6	15-20						
	3	137-147	505-525	6-11	17-22	8.6-10.6	15-20						

*Based on 15% Methanol antifreeze solution

060		Full Load Cooling - without HWG active						Full Load Heating - without HWG active					
Entering Water Temp °F	Water Flow GPM/ton	Suction Pressure PSIG	Discharge Pressure PSIG	Superheat	Subcooling	Water Temp Drop °F	Air Temp Drop °F DB	Suction Pressure PSIG	Discharge Pressure PSIG	Superheat	Subcooling	Water Temp Drop °F	Air Temp Rise °F DB
30*	1.5							64-74	309-329	7-12	10-15	8.4-10.4	19-24
	2.25							68-78	313-333	7-12	10-15	6.0-8.0	20-25
	3							71-81	317-337	8-13	10-15	3.6-5.6	20-25
50	1.5	120-130	225-245	9-14	13-18	21.8-23.8	20-25	94-104	343-363	9-14	12-18	11.3-13.3	25-30
	2.25	120-130	222-242	9-14	10-15	14.7-16.7	20-25	100-110	350-270	10-15	11-16	8.2-10.2	26-31
	3	118-128	220-240	9-14	9-14	8.7-10.7	20-25	105-115	356-376	10-15	10-15	5.0-8.0	26-31
70	1.5	124-134	300-320	8-13	14-19	19.9-21.9	19-24	122-132	377-397	11-16	9-14	14.2-16.2	31-36
	2.25	124-134	278-298	8-13	11-16	14.1-16.1	19-24	130-140	386-406	12-17	8-13	10.3-12.3	31-36
	3	123-133	256-276	8-13	9-14	8.3-10.3	19-24	137-147	394-414	13-18	7-12	6.5-8.5	33-38
90	1.5	130-140	420-440	7-12	16-21	19.0-21.0	17-22	155-165	412-432	14-19	6-11	17.2-19.2	36-41
	2.25	129-139	400-420	7-12	12-17	13.4-15.4	17-22	165-175	423-443	15-20	5-10	12.6-14.6	37-42
	3	129-139	390-410	7-12	9-14	7.9-9.9	17-22	175-185	423-443	16-21	4-9	7.9-9.9	39-44
110	1.5	133-143	495-515	6-11	16-21	18.5-20.5	16-21						
	2.25	132-142	475-495	6-11	13-18	13.1-15.1	16-21						
	3	132-142	454-474	6-11	9-14	7.6-9.6	16-21						

*Based on 15% Methanol antifreeze solution

PREVENTIVE MAINTENANCE

Water Coil Maintenance

(Direct ground water applications only)

If the system is installed in an area with a known high mineral content (125 P.P.M. or greater) in the water, it is best to establish a periodic maintenance schedule with the owner so the coil can be checked regularly. Consult the well water applications section of this manual for a more detailed water coil material selection. Should periodic coil cleaning be necessary, use standard coil cleaning procedures, which are compatible with the heat exchanger material and copper water lines. Generally, the more water flowing through the unit, the less chance for scaling. Therefore, 1.5 gpm per ton [2.0 l/m per kW] is recommended as a minimum flow. Minimum flow rate for entering water temperatures below 50°F [10°C] is 2.0 gpm per ton [2.6 l/m per kW].

Water Coil Maintenance

(All other water loop applications)

Generally water coil maintenance is not needed for closed loop systems. However, if the piping is known to have high dirt or debris content, it is best to establish a periodic maintenance schedule with the owner so the water coil can be checked regularly. Dirty installations are typically the result of deterioration of iron or galvanized piping or components in the system. Open cooling towers requiring heavy chemical treatment and mineral buildup through water use can also contribute to higher maintenance. Should periodic coil cleaning be necessary, use standard coil cleaning procedures, which are compatible with both the heat exchanger material and copper water lines. Generally, the more water flowing through the unit, the less chance for scaling. However, flow rates over 3 gpm per ton (3.9 l/m per kW) can produce water (or debris) velocities that can erode the heat exchanger wall and ultimately produce leaks.

Hot Water Generator Coils

See water coil maintenance for ground water units. If the potable water is hard or not chemically softened, the high temperatures of the desuperheater will tend to scale even quicker than the water coil and may need more frequent inspections. In areas with extremely hard water, a HWG is not recommended.

Filters

Filters must be clean to obtain maximum performance. Filters should be inspected every month under normal operating conditions and be replaced when necessary. Units should never be operated without a filter.

Washable, high efficiency, electrostatic filters, when dirty, can exhibit a very high pressure drop for the fan motor and reduce air flow, resulting in poor performance. It is especially important to provide consistent washing of these filters (in the opposite direction of the normal air flow) once per month using a high pressure wash similar to those found at self-serve car washes.

Condensate Drain

In areas where airborne bacteria may produce a "slimy" substance in the drain pan, it may be necessary to treat the drain pan chemically with an algaecide approximately every three months to minimize the problem. The condensate pan may also need to be cleaned periodically to insure indoor air quality. The condensate drain can pick up lint and dirt, especially with dirty filters. Inspect the drain twice a year to avoid the possibility of plugging and eventual overflow.

Compressor

Conduct annual amperage checks to insure that amp draw is no more than 10% greater than indicated on the serial plate data.

Fan Motors

All units have lubricated fan motors. Fan motors should never be lubricated unless obvious, dry operation is suspected. Periodic maintenance oiling is not recommended, as it will result in dirt accumulating in the excess oil and cause eventual motor failure. Conduct annual dry operation check and amperage check to insure amp draw is no more than 10% greater than indicated on serial plate data.

Air Coil

The air coil must be cleaned to obtain maximum performance. Check once a year under normal operating conditions and, if dirty, brush or vacuum clean. Care must be taken not to damage the aluminum fins while cleaning. CAUTION: Fin edges are sharp.

Cabinet

Do not allow water to stay in contact with the cabinet for long periods of time to prevent corrosion of the cabinet sheet metal. Generally, vertical cabinets are set up from the floor a few inches [7 - 8 cm] to prevent water from entering the cabinet. The cabinet can be cleaned using a mild detergent.

Refrigerant System

To maintain sealed circuit integrity, do not install service gauges unless unit operation appears abnormal. Reference the operating charts for pressures and temperatures. Verify that air and water flow rates are at proper levels before servicing the refrigerant circuit.

TROUBLESHOOTING

General

If operational difficulties are encountered, perform the preliminary checks below before referring to the troubleshooting charts.

- Verify that the unit is receiving electrical supply power.
- Make sure the fuses in the fused disconnect switches are intact.

After completing the preliminary checks described above, inspect for other obvious problems such as leaking connections, broken or disconnected wires, etc. If everything appears to be in order, but the unit still fails to operate properly, refer to the “DXM2 Troubleshooting Process Flowchart” or “Functional Troubleshooting Chart.”

DXM2 Board

DXM2 board troubleshooting in general is best summarized as verifying inputs and outputs. After inputs and outputs have been verified, board operation is confirmed and the problem must be elsewhere. Below are some general guidelines for troubleshooting the DXM2 control.

Field Inputs

Conventional thermostat inputs are 24VAC from the thermostat and can be verified using a voltmeter between C and Y1, Y2, W, O, G. 24VAC will be present at the terminal (for example, between “Y1” and “C”) if the thermostat is sending an input to the DXM2 board.

Proper communications with a thermostat can be verified using the Fault LED on the DXM2. If the control is NOT in the Test mode and is NOT currently locked out or in a retry delay, the Fault LED on the DXM2 will flash very slowly (1 second on, 5 seconds off), if the DXM2 is properly communicating with the thermostat.

Sensor Inputs

All sensor inputs are ‘paired wires’ connecting each component to the board. Therefore, continuity on pressure switches, for example can be checked at the board connector. The thermistor resistance should be measured with the connector removed so that only the impedance of the thermistor is measured. If desired, this reading can be compared to the thermistor resistance chart shown in the DXM2 AOM manual. An ice bath can be used to check the calibration of the thermistor.

Outputs

The compressor and reversing valve relays are 24VAC and can be verified using a voltmeter. For units with PSC blower motors, the fan relay provides a contact closure to directly power the blower motor, or provide 24VAC to an external fan relay. For units with ECM blower motors, the DXM2 controls the motor using serial communications, and troubleshooting should be done with a communicating thermostat or diagnostic tool. The alarm relay can either be 24VAC as shipped or dry contacts for use with DDC controls by clipping the JW1 jumper. Electric heat outputs are 24VDC “ground sinking” and require a voltmeter set for DC to verify operation. The terminal marked “24VDC” is the

24VDC supply to the electric heat board; terminal “EH1” is stage 1 electric heat; terminal “EH2” is stage 2 electric heat. When electric heat is energized (thermostat is sending a “W” input to the DXM2 controller), there will be 24VDC between terminal “24VDC” and “EH1” (stage 1 electric heat) and/or “EH2” (stage 2 electric heat). A reading of 0VDC between “24VDC” and “EH1” or “EH2” will indicate that the DXM2 board is NOT sending an output signal to the electric heat board.

Test Mode

Test mode can be entered for 20 minutes by pressing the Test pushbutton. The DXM2 board will automatically exit test mode after 20 minutes.

Advanced Diagnostics

If a communicating thermostat or diagnostic tool is connected to the DXM2, additional diagnostic information and troubleshooting capabilities are available. The current status of all DXM2 inputs can be verified, including the current temperature readings of all temperature inputs. With a communicating thermostat the current status of the inputs can be accessed from the Service Information menu. In the manual operating mode, most DXM2 outputs can be directly controlled for system troubleshooting. With a communicating thermostat the manual operating mode can be accessed from the Installer menu. For more detailed information on the advanced diagnostics of the DXM2, see the DXM2 Application, Operation and Maintenance (AOM) manual (part #97B0003N15).

DXM2 Troubleshooting Process Flowchart/Functional Troubleshooting Chart

The “DXM2 Functional Troubleshooting Process Flowchart” is a quick overview of how to start diagnosing a suspected problem, using the fault recognition features of the DXM2 board. The “Functional Troubleshooting Chart” on the following page is a more comprehensive method for identifying a number of malfunctions that may occur, and is not limited to just the DXM2 controls. Within the chart are five columns:

- The “Fault” column describes the symptoms.
- Columns 2 and 3 identify in which mode the fault is likely to occur, heating or cooling.
- The “Possible Cause column” identifies the most likely sources of the problem.
- The “Solution” column describes what should be done to correct the problem.

⚠ WARNING! ⚠

WARNING! HAZARDOUS VOLTAGE! DISCONNECT ALL ELECTRIC POWER INCLUDING REMOTE DISCONNECTS BEFORE SERVICING.
Failure to disconnect power before servicing can cause severe personal injury or death.

DXM2 PROCESS FLOW CHART

⚠ WARNING! ⚠

WARNING! HAZARDOUS VOLTAGE! DISCONNECT ALL ELECTRIC POWER INCLUDING REMOTE DISCONNECTS BEFORE SERVICING. Failure to disconnect power before servicing can cause severe personal injury or death.

DXM2 Functional Troubleshooting Flow Chart

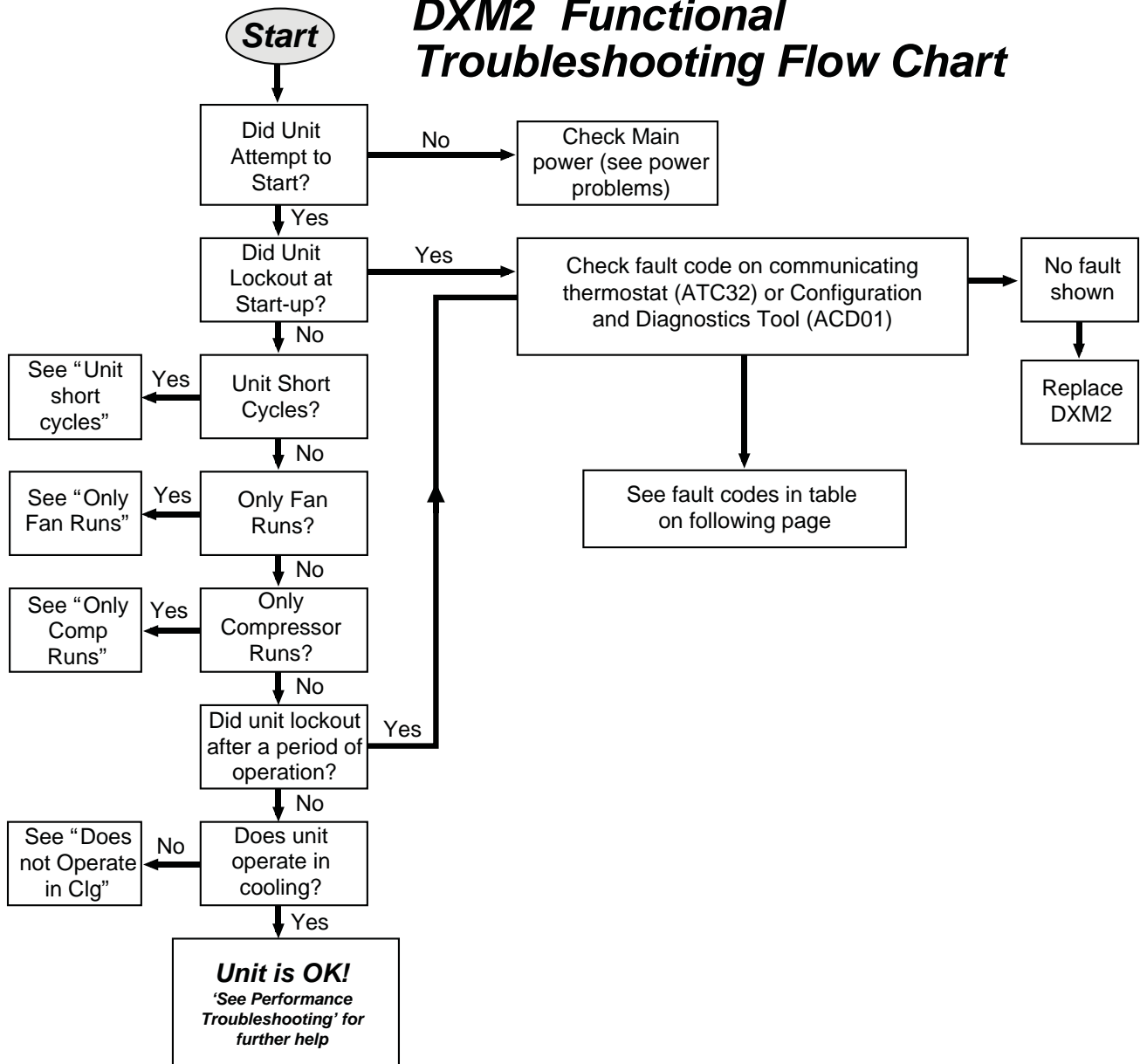

FUNCTIONAL TROUBLESHOOTING

Fault	Htg	Clg	Possible Cause	Solution
Main Power Problems	X	X	Green status LED off	Check Line Voltage circuit breaker and disconnect
				Check for line voltage between L1 and L2 on the contactor
HP Fault Code 2 High Pressure		X	Reduced or no water flow in cooling	Check for 24VAC between R and C on DXM
				Check primary/secondary voltage on transformer
		X	Water temperature out of range in cooling	Check pump operation or valve operation/setting
				Check water flow adjust to proper flow rate
	X		Reduced or no air flow in heating	Bring water temp within design parameters
				Check for dirty air filter and clean or replace
	X	X	Overcharged with refrigerant	Check fan motor operation and airflow restrictions
				Dirty air coil- construction dust etc.
X		Air temperature out of range in heating	Too high of external static. Check static vs blower table	
			Bring return air temp within design parameters	
X	X	Bad HP switch	Check superheat/subcooling vs typical operating condition table	
			Check switch continuity and operation - Replace	
X	X	Frozen water heat exchanger	Thaw heat exchanger	
			Replace HPWS Switch	
LP/LOC Fault-Code 3 Low Pressure/Loss of Charge	X	X	Insufficient charge	Check for refrigerant leaks
				Compressor pump down at start-up
LT1 Fault - Code 4 Water Low Temperature	X		Reduced or no water flow in heating	Check charge and start-up water flow
				Check pump operation or water valve operation/setting
	X		Inadequate anti-freeze level	Plugged strainer or filter - clean or replace
				Check water flow adjust to proper flow rate
	X		Improper low temperature setting (30°F vs 10°F)	Check antifreeze density with hydrometer
Clip LT1 jumper for antifreeze (10°F) use				
X	X	Bad thermistor	Bring water temp within design parameters	
			Check temp and impedance correlation per chart	
LT2 Fault - Code 5 Low Air Temperature		X	Reduced or no air flow in cooling	Check for dirty air filter and clean or replace
				Check fan motor operation and airflow restrictions
		X	Air temperature out of range	Too high of external static - check static vs blower table
				Too much cold vent air - bring entering air temp within design parameters
X	X	Bad thermistor	Normal airside applications will require 30°F only	
			Check temp and impedance correlation per chart	
Condensate Fault-Code 6 High Condensate Level	X	X	Blocked drain	Check for blockage and clean drain
				Improper trap
		X	Poor drainage	Check trap dimensions and location ahead of vent
				Check for piping slope away from unit
	X	X	Plugged air filter	Check slope of unit toward outlet
				Poor venting - check vent location
X	X	Restricted return air flow	Check for moisture shorting to air coil	
			Replace air filter	
Over/Under Voltage-Code 7 (Auto Resetting)	X	X	Under voltage	Find and eliminate restriction - increase return duct and/or grille size
				Check power supply and 24VAC voltage before and during operation
	X	X	Over voltage	Check power supply wire size
				Check compressor starting. Need hard start kit?
Unit Performance Sentinel-Code 8	X		Heating Mode LT2>125°F	Check 24VAC and unit transformer tap for correct power supply voltage
				Cooling Mode LT1>125°F OR LT2< 40°F
Swapped Thermistor Code 9	X	X	LT1 and LT2 swapped	Check power supply voltage and 24VAC before and during operation.
				Check 24VAC and unit transformer tap for correct power supply voltage
ECM Fault - Code 10	X	X	Blower does not operate	Check for poor air flow or overcharged unit
				Check blower line voltage
			Blower operating with incorrect airflow	Check blower low voltage wiring
				Wrong unit size selection
				Wrong unit family selection
Wrong motor size				
Incorrect blower selection				

FUNCTIONAL TROUBLESHOOTING (CONT.)

Fault	Htg	Clg	Possible Cause	Solution
IFC Fault Code 13 Internal Flow Controller Fault	X	X	No pump output signal	Check DC voltage between A02 and GND - should be between 0.5 and 10 VDC with pump active
			Low pump voltage	Check line voltage to the pump
			No pump feedback signal	Check DC voltage between T1 and GND. Voltage should be between 3 and 4 VDC with pump OFF, and between 0 and 2 VDC with the pump ON
			Bad pump RPM sensor	Replace pump if the line voltage and control signals are present at the pump, and the pump does not operate
ESD - ERV Fault (DXM Only) Green Status LED Code 3	X	X	ERV unit has fault (Rooftop units only)	Troubleshoot ERV unit fault
No Fault Code Shown	X	X	No compressor operation	See 'Only Fan Operates'
	X	X	Compressor overload	Check and replace if necessary
	X	X	Control board	Reset power and check operation
Unit Short Cycles	X	X	Dirty air filter	Check and clean air filter
	X	X	Unit in 'Test Mode'	Reset power or wait 20 minutes for auto exit
	X	X	Unit selection	Unit may be oversized for space - check sizing for actual load of space
	X	X	Compressor overload	Check and replace if necessary
Only Fan Runs	X	X	Thermostat position	Insure thermostat set for heating or cooling operation
	X	X	Unit locked out	Check for lockout codes - reset power
	X	X	Compressor overload	Check compressor overload - replace if necessary
	X	X	Thermostat wiring	Check thermostat wiring at DXM2 - put in Test Mode and jumper Y1 and R to give call for compressor

TROUBLESHOOTING FORM

HEATING CYCLE ANALYSIS -

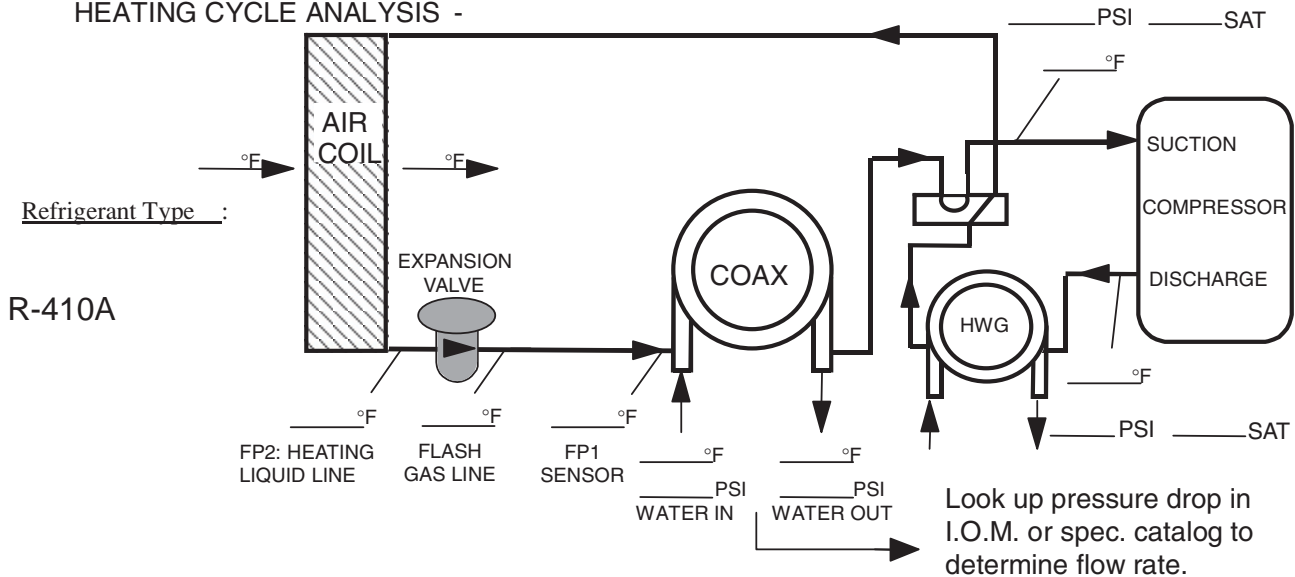

COOLING CYCLE ANALYSIS -

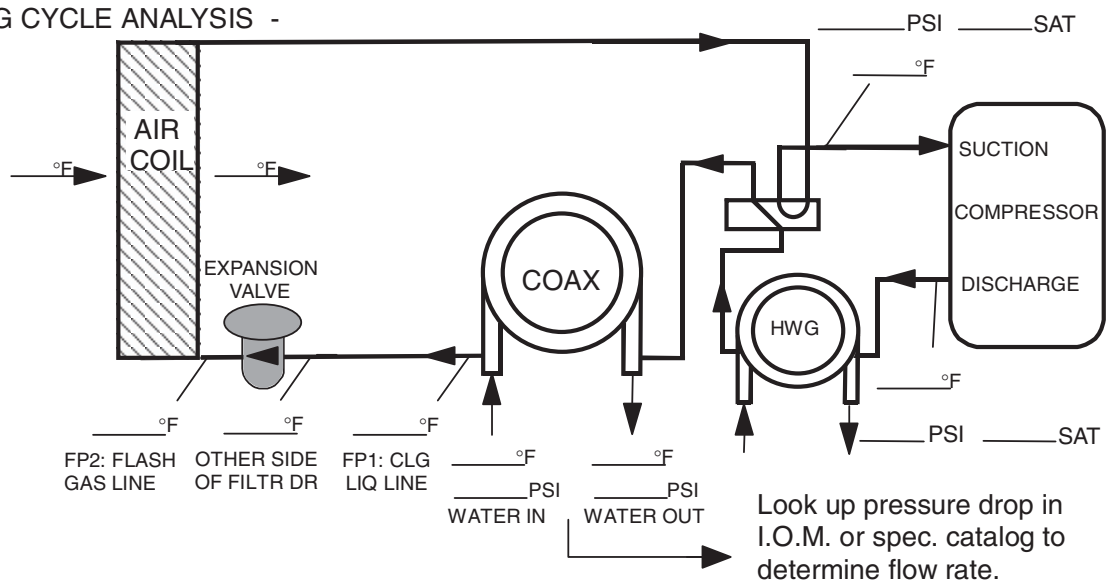

Heat of Extraction (Absorption) or Heat of Rejection =

_____ flow rate (gpm) x _____ temp.diff. (deg. F) x _____ fluid factor[†] = _____ (Btu/hr)

Superheat = Suction temperature - suction saturation temp. = _____ (deg F)

Subcooling = Discharge saturation temp. - liquid line temp. = _____ (deg F)

[†]Use 500 for water, 485 for antifreeze.

Note: Never connect refrigerant gauges during startup procedures. Conduct water-side analysis using P/T ports to determine water flow and temperature difference. If water-side analysis shows poor performance, refrigerant troubleshooting may be required. Connect refrigerant gauges as a last resort.

Revision History

Date	Page #	Description
22 April, 13	All	024, 036 Rev B Info Added

Design, material, performance data and components
subject to change without notice.

HEAT CONTROLLER, INC.

1900 Wellworth Ave., Jackson, MI 49203 • Ph. 517-787-2100 • Fax 517-787-9341

THE QUALITY LEADER IN CONDITIONING AIR

www.heatcontroller.com



97B0016N11